

Full-Body Pregnancy Simulator II

LM-114H-CE

Instruction Manual

Thank you for purchasing the Full-Body Pregnancy Simulator II.
Please read this instruction manual carefully to ensure correct use of the product,
and store it in a safe place for easy access.

Manufacturer:

KOKEN CO., LTD.

1-4-14 Koraku, Bunkyo-ku, Tokyo 112-0004 JAPAN
www.kokenmpc.co.jp



EU Authorized Representative for KOKEN CO., LTD.:

EC REP

MDSS GmbH
Schiffgraben 41
30175 Hannover, Germany
www.mdssar.com





Handling and Safety Precautions

These precautions should be strictly observed in order to ensure safe, long-term use of the product.

The following precautions should be observed particularly strictly:

1. Please handle this model with the same care that you would exercise when working with a human body. Excessive force may damage the model.
2. Do not use oil-based inks, pencil, chalk, or paints on the model as they will soak into the material and cannot be removed.
3. In caring for the model, do not clean the model with rubbing alcohol, thinners, benzene or other similar organic solvents.
4. Use glycerin to lubricate the models. Be sure to apply a sufficient amount of lubricant (glycerin) to the model before use. Koken is not responsible for deterioration or damage occurring from use of lubricants other than glycerin. Use commercially available glycerin if you run out of the glycerin provided with the model.
5. Please do not use oily lubricant (baby oil, olive oil etc.), alcohol lubricant, and lubricant containing organic solvent. These may cause breakage of the model.
6. Placing objects directly on top of the model or placing it on uneven surfaces may cause deformation.
7. Store the model in a 0-50°C environment, in a place where it will not be exposed to direct sunlight or UV rays.
※ Storing the abdominal wall piece for an extended time in a high or low temperature environment may cause the oil component to ooze out, causing deformation or discoloration. If possible, store at 10-50°C .
8. This model uses urethane foam for some of its parts, and may be susceptible to damage from pests that are attracted to urethane foam (such as insects in the ant family).
When storing this model, ensure that thorough measures are taken to prevent pest damage before storing. The company will not be involved with or held liable for pest damage that occurs during storage.
9. This product is intended for use in standard operating environments. Do not use it in heavy industrial settings.
10. Please read these handling precautions for each part on the following pages.

11. About the AC Adapter

This model does not come with an AC adapter.

Please use an AC adapter with the following specifications.

EMC Directive	EMS: EN61000-6-1 or EN61000-6-2
	EMI: EN61000-6-3
	or EN61000-3-2 and EN61000-3-3
	and EN55032 class B or EN55011 group1 class B
LV Directive:	EN62368
RoHS Directive:	EN IEC 63000
Rated Output :	15VDC 1.2A
Rated Input :	AC100 - 240V 50/60Hz
Plug Shape :	Inner diameter \varnothing 2.1mm/Outer diameter \varnothing 5.5mm
	Center minus (+)  (-)

1. The contents of this instruction manual are subject to change without notice.
2. This instruction manual may not be reproduced in part or in its entirety without permission.
3. Please contact the manufacturer in the event that any errors or omissions are found in the contents of this instruction manual.
4. This product should be used only as described in this instruction manual. In particular, the product should not be used in any way that contravenes the precautions noted in the instruction manual.

Table of Contents

1.	Overview, Features and Development	4
2.	Name and Configuration of Each Model.....	6
3.	Full-body Manikin Handling Precautions	7
4.	Parts of the Full-body Manikin	7
5.	Using the Full-body Manikin.....	8
6.	Obstetric Abdominal Palpation Model Handling Precautions.....	10
7.	Parts of the Obstetric Abdominal Palpation Model	11
8.	Using the Obstetric Abdominal Palpation Model	12
9.	Caring for the Obstetric Abdominal Palpation Model	18
10.	Vaginal Examination Model Handling Precautions	19
11.	Parts of the Vaginal Examination Model.....	20
12.	Using the Vaginal Examination Model	21
13.	Caring for the Vaginal Examination Model	25
14.	Obstetric Assistant Model Handling Precautions	26
15.	Parts of the Obstetric Assistant Model	28
16.	Using the Obstetric Assistant Model.....	29
17.	Caring for the Obstetric Assistant Model.....	37
18.	Perineal Suture Model Handling Precautions.....	38
19.	Parts of the Perineal Suture Model.....	39
20.	Using the Perineal Suture Model	40
21.	Puerperal Uterus Palpation Model Handling Precautions	42
22.	Parts of the Puerperal Uterus Palpation Model.....	43
23.	Using the Puerperal Uterus Palpation Model	44
24.	Caring for the Puerperal Uterus Palpation Model.....	46
25.	List of Parts.....	46
26.	Specifications	47
27.	Optional Items.....	48
28.	Storing the Vaginal Examination Model, Obstetric Assistant Model, and Perineal Suture Model.....	49
29.	Precautions for Unpacking and Storing	50

1. Overview, Features and Development

Outline

- By interchanging various parts, procedures such as external examination of a pregnant woman, internal examination during stages of delivery, practical obstetric assistance, perineal suture of soft birth canal lacerations, palpation of the uterus fundus during the puerperal period, and breast care can be practiced. Trainees can practice a series of techniques based on the L.D.R. concept (Labor, Delivery, and Recovery) using a life size full-body model.
- Each part is made with a special material to simulate the texture of human skin.
- Obstetric assistance can be practiced on the model in either a supine or free-style position.

Features

Obstetric Abdominal Palpation Model

- Represents the 36th to 40th weeks of pregnancy.
- Visual diagnosis, palpation and abdominal measurements (abdominal girth, fundal height) according to the four types of Leopold's Maneuvers, monitoring of fetal heartbeats, and breast care can be practiced.
- Changing the position and orientation of the fetus enables diagnosis in various fetal positions and orientations, and diagnosis of stability and mobility of the fetal presenting part.
- The fetal heartbeat can be adjusted between 80 and 180 bpm.

Vaginal Examination Model

- Bishop scores from the late stage of pregnancy to the onset of labor (cervical dilation, effacement, consistency and position) can be confirmed.
- Made with a material that is more tear-resistant than the previous model, increasing its durability.
- Three models with varying degrees of cervical dilation are provided, together with a full dilation model. These can be interchanged and the station can be adjusted, thereby allowing the assessment of the progression of labor by means of a vaginal examination.
- The full dilation model can be used to gauge orientation of the fetal head by palpation of the positions of the sagittal sutures and posterior fontanel.
- The vulva has a urethral orifice for inserting a urinary catheter.

Obstetric Assistant Model

- By changing between various positions, including supine, hands and knees, lateral, and standing, the fetal model can be rotated according to each position, providing several positions for obstetric assistant practice (Free-style delivery).
- The obstetric model - vulva II is made with a highly elastic and durable material that decreases resistance and reduces the amount of force needed to extract the fetus during delivery, enabling smooth practice. (Use glycerin to lubricate.)
- Protection of the perineum can be practiced.
- Breech extraction can also be practiced as one type of emergency response.
- The head of the fetal model has been improved to create a more realistic shape and texture. The neck moves flexibly so that the model can be seen from the posterior fontanelle during

crowning. The structure and shape of the neck, corners of the mouth, and umbilical region, where damage is most common, have been improved to reduce the risk of damage.

- The fetal head allows suction cups (soft type) to be used so that procedures such as vacuum and forceps delivery can be practiced.
- The umbilical cord of the new placenta model has improved durability, and enables the use of Kocher forceps and umbilical cord clip. Moreover, the model can be used to simulate nuchal cord, and can be attached to parts that are sold separately to practice tying and cutting the umbilical cord.
- The structure and material of the placenta has been improved, making it easier to remove during delivery, and reducing the risk of damage.

Perineal Suture Model

- This model enables confirmation of the perineal laceration position and level of laceration, and practice in preparing for and performing a suture.
- Use of forceps can also be practiced.

Puerperal Uterus Palpation Model

- Four kinds of puerperal uterus models are provided (normal and abnormal conditions on the first day, normal conditions on the third day and on the fifth day). These can be interchanged for diagnosis of progress in involution of the uterus through palpation and measurement of the abdominal area.

Breast Model

- This model enables basic training in breast care, including breast and nipple palpation, inspection of breast mobility, and nipple massage.
- Flexibility and mobility of the entire breast allows palpation of the mammary glands.

Development of the full body pregnancy simulator

The full body pregnancy simulator was developed by Dr. Mieko Hirasawa, Dr. Megumi Matsuoka, Dr. Hiroko Ando, and Dr. Keiko Suzuki from 1997 to 1998 during a two-year program funded by a Ministry of Education, Science, Sports and Culture Grant-in-Aid for Scientific Research.

The aim of this research was to develop a model for training in inspection, diagnosis, and care of expectant and nursing mothers, skills of which are essential in nursing and midwifery. Specifically, the end result would be a practical simulator that allows flexible practice of care and inspection of a pregnant or puerperal patient to match the training purpose, including breast inspection and care, Leopold's Maneuvers, fetal heartbeat monitoring, urethral catheterization, vaginal examination at the onset of labor, cleaning of external genitalia, and obstetric assistance in free-style position.

2. Name and Configuration of Each Model

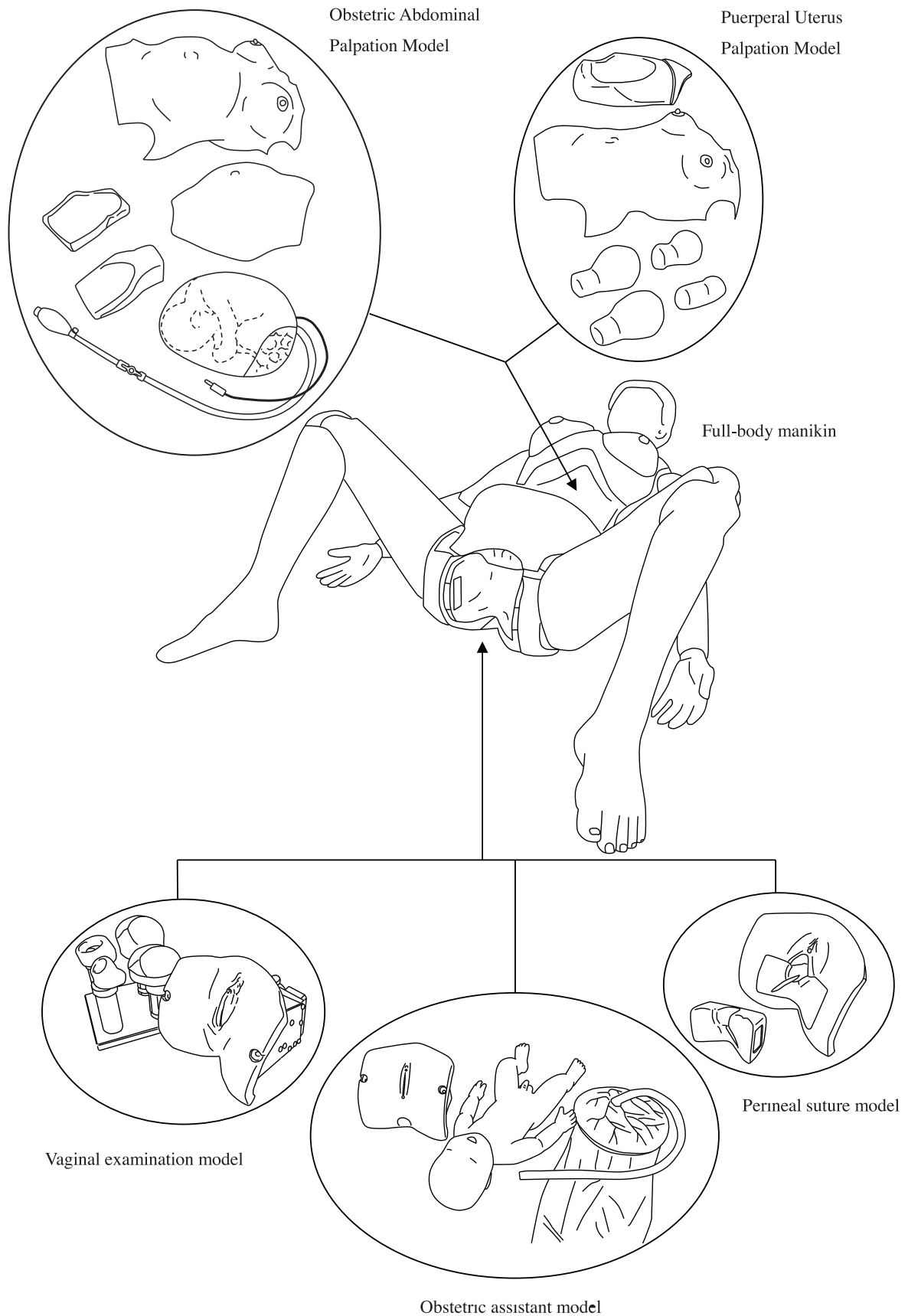

3. Full-body Manikin Handling Precautions

1. To clean smudges or marks, wipe with a moist gauze or similar material using water or a neutral solvent diluted with water.
*Do not clean the model with rubbing alcohol, thinners, benzene or other similar solvents.
2. Dropping the model or subjecting it to strong impact could cause damage.
3. Store the model in a place where it will not be exposed to direct sunlight or UV rays.

4. Parts of the Full-body Manikin

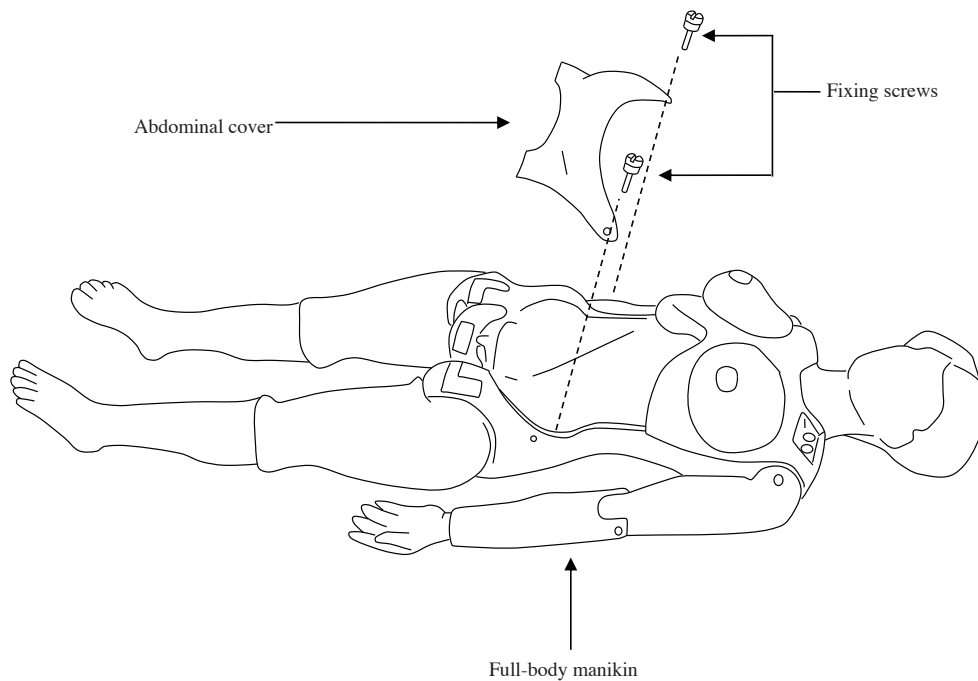

5. Using the Full-body Manikin

5-1. Attaching the abdominal cover

Set the abdominal cover on the full-body manikin, affix it to the hook and loop fasteners on the leg side, and secure it in place on the abdomen side with the fixing screws.

(The abdominal cover is used when practicing vaginal examination and delivery.)

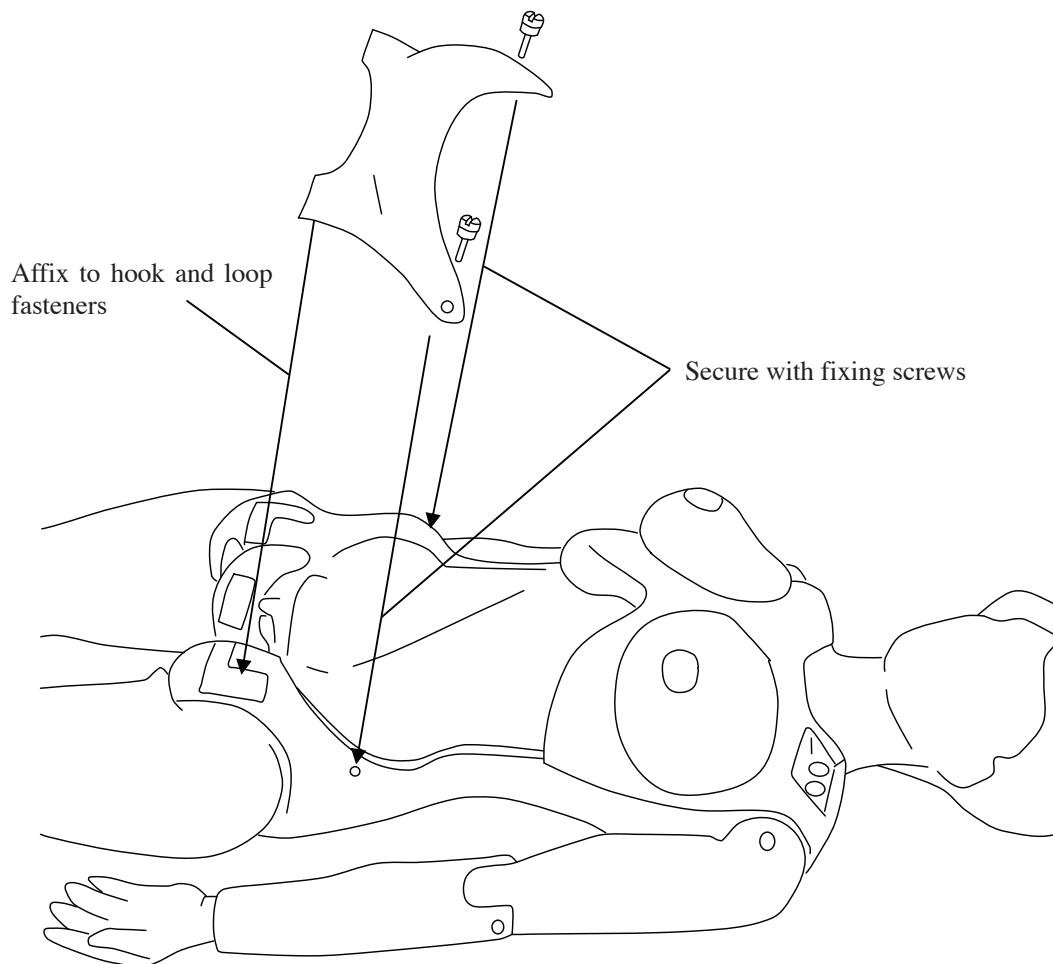

5-2. Fixing the leg position

As shown in the diagram below, peel back the skin of the leg and pull the leg-fixing lever upwards to fix it in position.

(Both legs can be fixed into position in the same manner.)

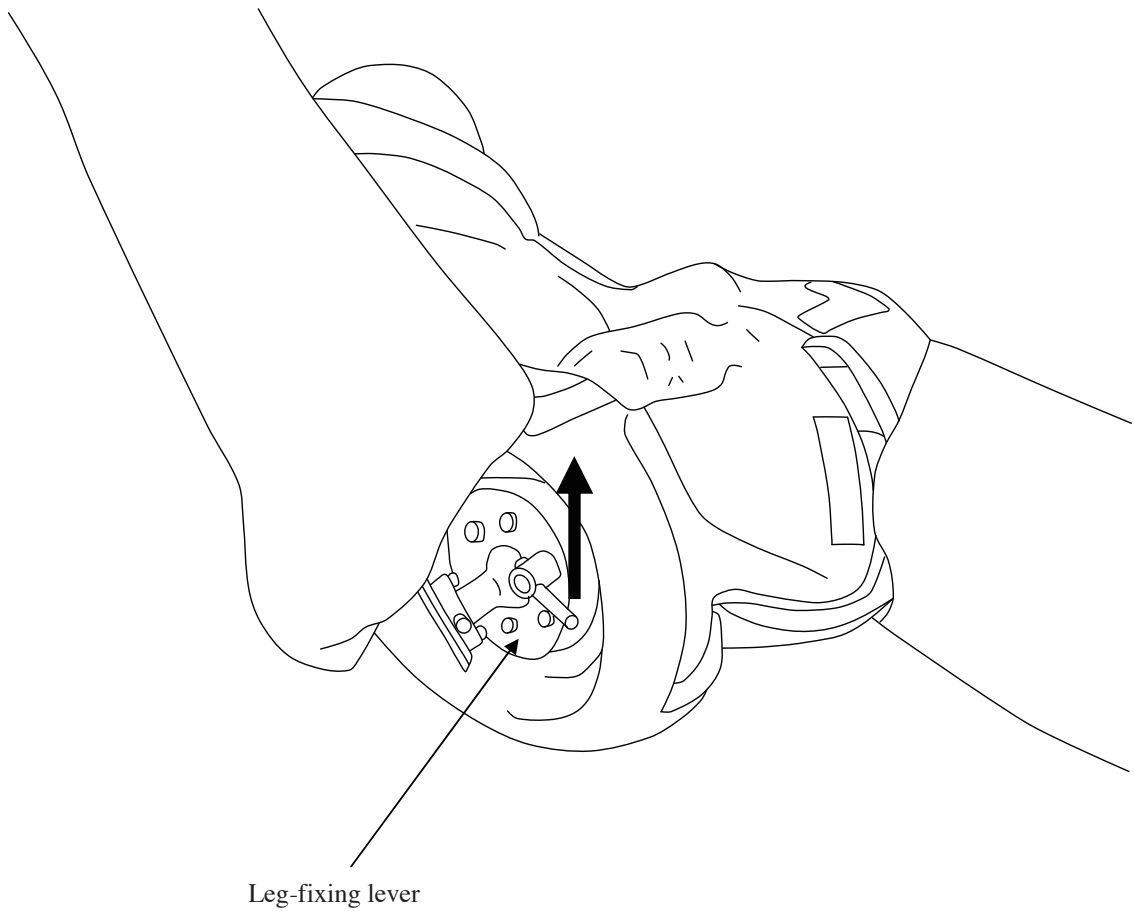

6. Obstetric Abdominal Palpation Model Handling Precautions

1. Please handle this model with the same care that you would exercise when working with a human body. Excessive force may result in damage.
2. Dropping the model or subjecting it to a strong impact may cause damage.
3. The material of the abdominal wall piece has a distinct odor. This odor is not harmful to the human body and does not indicate poor quality. The distinct odor fades over time. There may also be a smell of baby powder remaining on the product, as baby powder is applied to the models during fabrication.
4. The abdominal wall piece may become sticky due to the oil component. Always wrap the abdominal part correctly in the protective sheet (provided as an accessory) and then place it in the storage bag. If it becomes too sticky after use or after washing, it may be difficult to set the skin in place. In these cases, apply baby powder (provided as an accessory) liberally to the abdominal wall piece.
5. The skin may become sticky from the oil component in the abdominal wall piece. If this happens, wash the skin in water to remove the oil before use. To prevent the oil from getting onto the skin, always wrap the abdominal wall piece correctly in the protective sheet (provided as an accessory) and then place it in the storage bag.
6. The abdominal wall piece may change its shape over a prolonged period. Check the shape of the part about three years after purchase. If it is deformed to the extent that its function is affected, consider replacing it.
7. Air bubbles or impressions in the abdominal wall piece that may remain from the fabrication process do not affect the strength of the material, as the material used is tear-resistant.
8. Do not use oil-based inks, pencil, chalk, or paints on the model because they will soak into the material and may cause permanent staining.
9. Do not use the model outdoors or in damp places; doing so may damage the model.
10. When excessive amount of air is injected into the amnion, the amnion may burst. Inject air while checking the tension of the amnion by touching the abdomen of the model.
11. Placing objects directly on top of the models or placing them on uneven surfaces may cause deformation.
12. Storing the model for an extended period in a high or low temperature environment or under exposure to direct sunlight may cause the oil component in the abdominal wall piece to ooze out, causing deformation or discoloration of the model. If possible, store the model at 10°C to 50°C, away from direct sunlight.
13. When storing the Seitz method standard adjustment base and Seitz method plus adjustment base in the parts storage bag, always place them in the bags in which they came at the time of purchase.

7. Parts of the Obstetric Abdominal Palpation Model

Skin II for obstetric abdominal palpation model

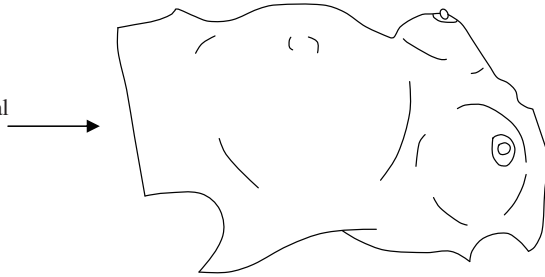

Abdominal wall piece

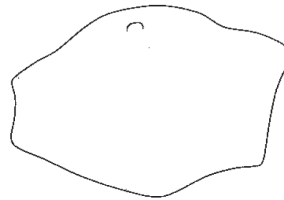

Fetus model with amnion
(with two-way stopcock)

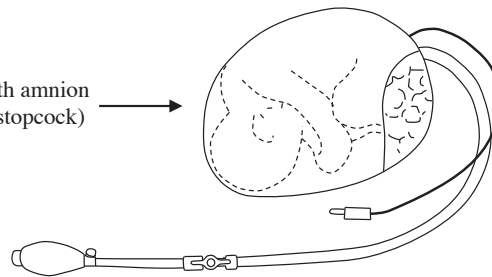

Seitz method standard
adjustment base

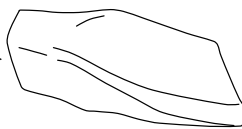

Seitz method plus
adjustment base

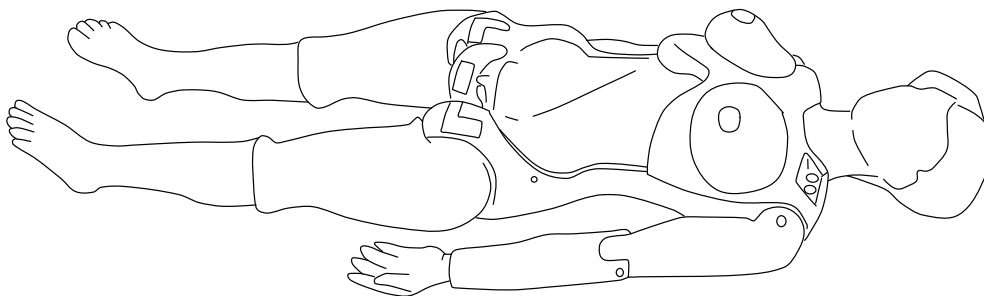

Full-body manikin

8. Using the Obstetric Abdominal Palpation Model

8-1. Attaching the Seitz method adjustment base and fetus model with amnion

Place the Seitz method adjustment base on the abdomen of the full-body manikin, and set the fetus model with amnion on the abdomen.

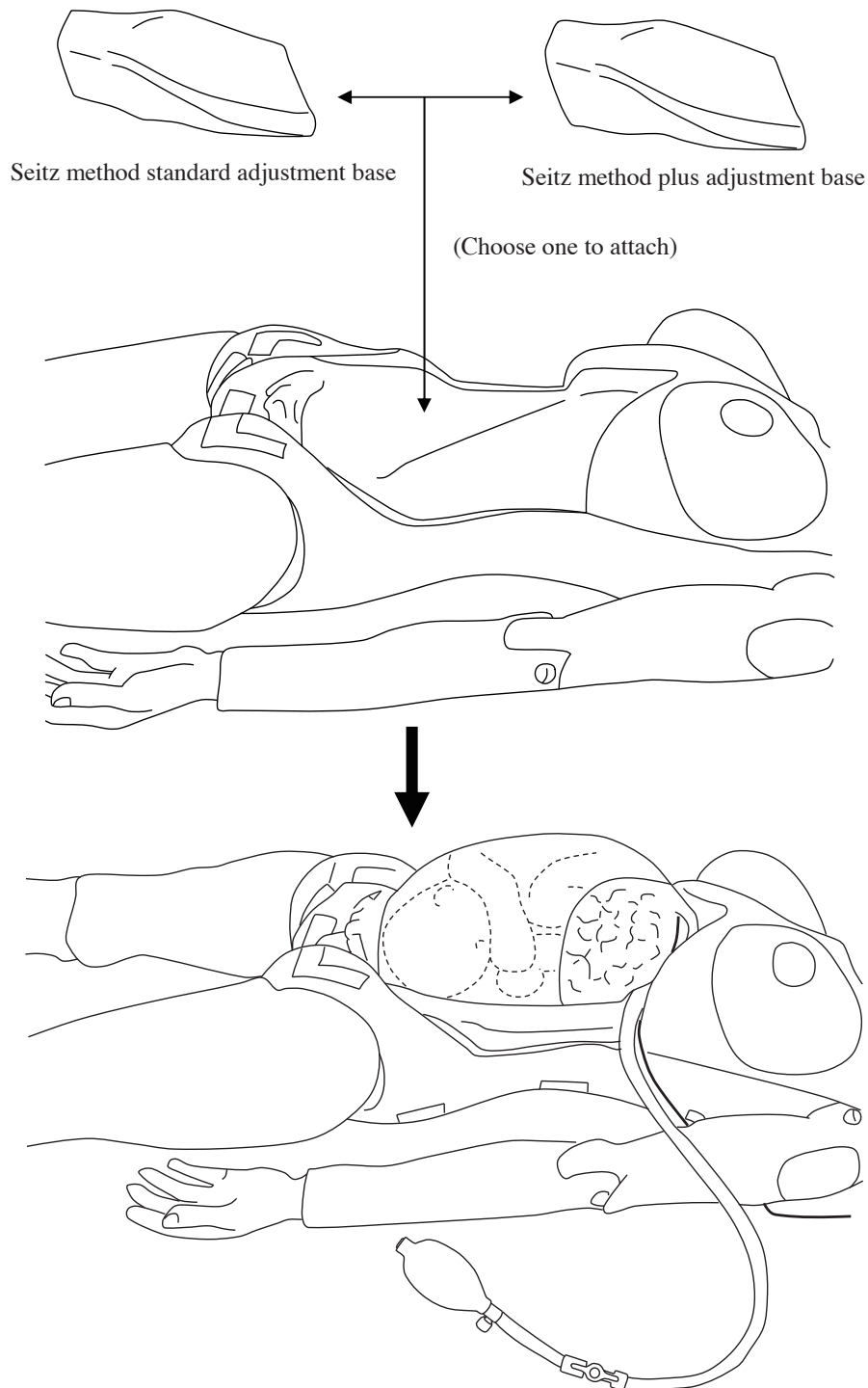

8-2. Connecting the fetus model with amnion

Connect the extension cord for heartbeat generator of the heartbeat cord of the fetus model with amnion, then connect it to the shoulder panel.

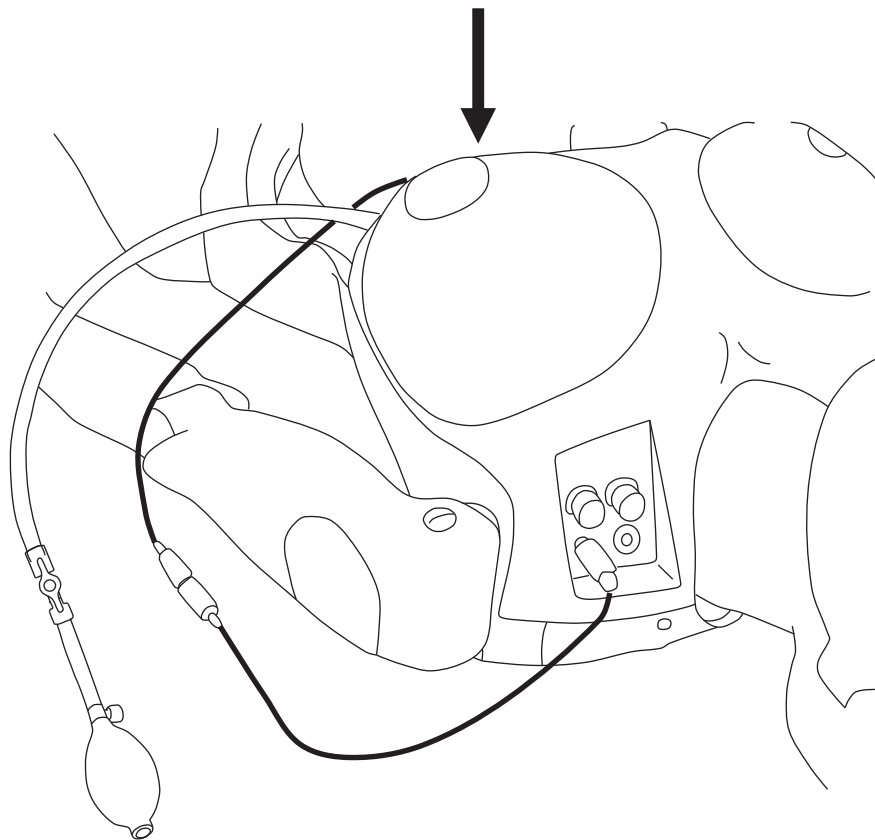
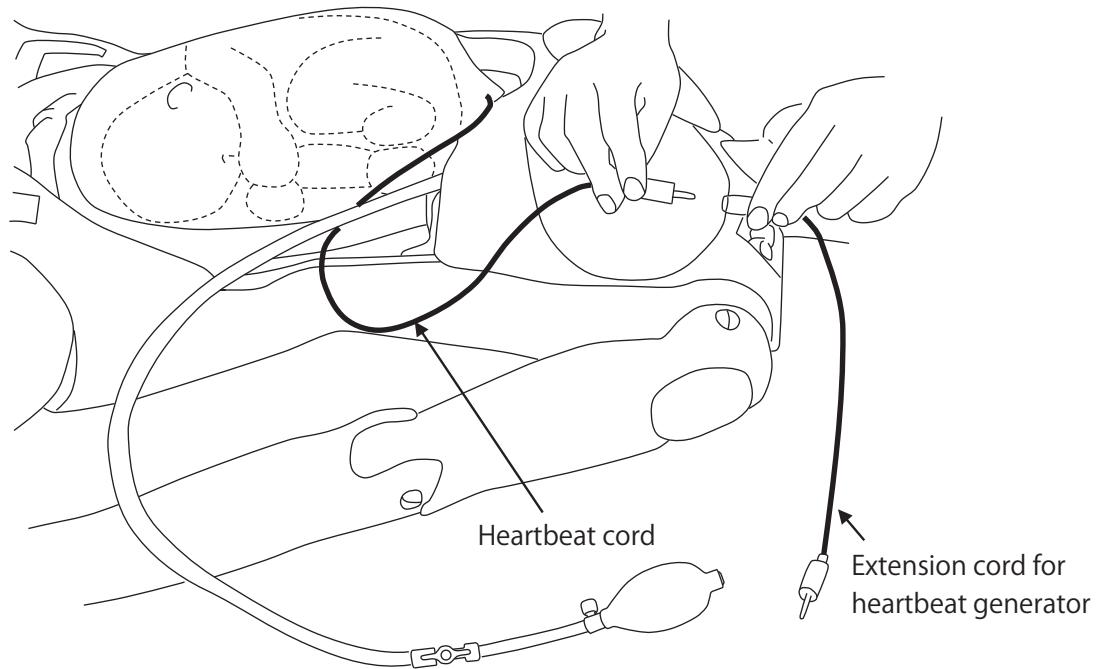

8-3. Explanation of the shoulder panel part

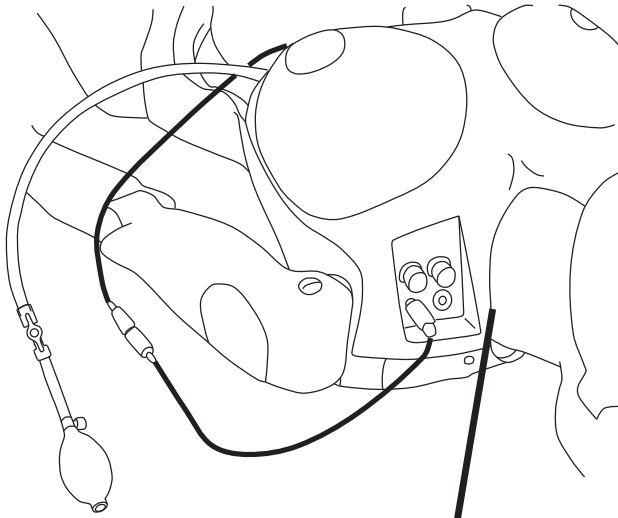

Enlargement of shoulder panel

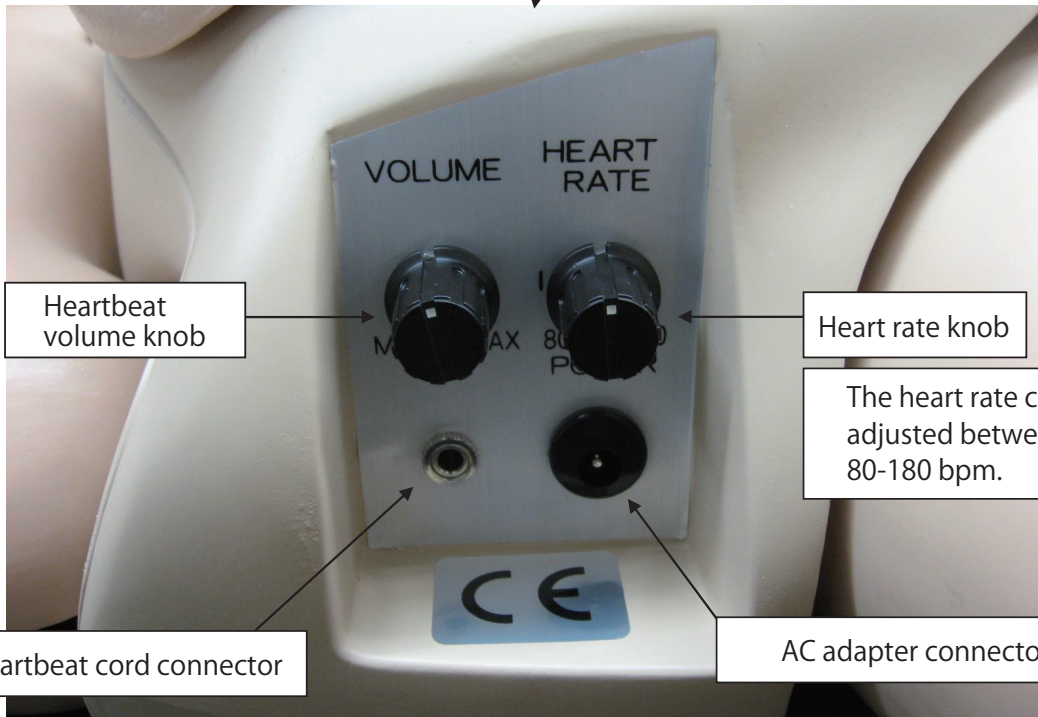

*Plug the AC adapter into an outlet, and insert the other end into the connector for the AC adapter shown above.

This model does not come with an AC adapter.

Please see page 2 about the AC adapter.

8-4. Attaching the Skin II for obstetric abdominal palpation model and Abdominal wall piece

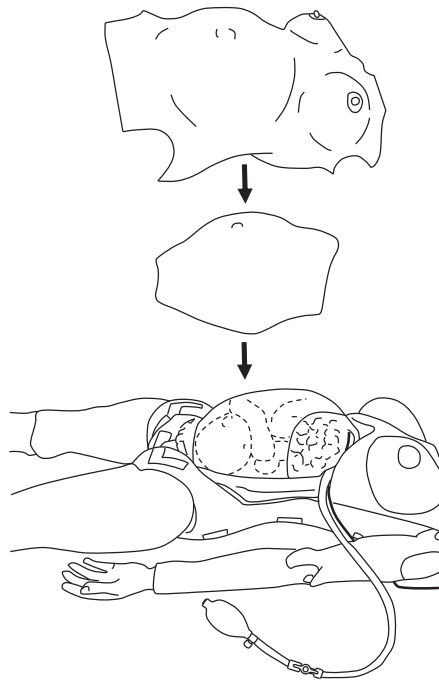

- (1) Set the abdominal wall piece in place, open the two-way stopcock and fill the amnion of the fetus model with air. Inject air by pushing the rubber bladder about 30 times. If the abdominal wall piece slips out of place after filling the amnion with air, be sure to restore it to the correct position.

*After setting the skin in place, adjust the volume of air in the amnion.

* The abdominal wall piece has an external surface and an internal surface and a superior end (towards the head) and an inferior end (towards the legs). Be sure that it is orientated correctly.

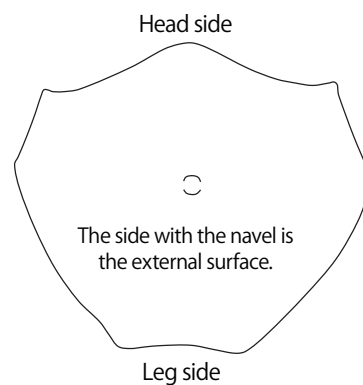
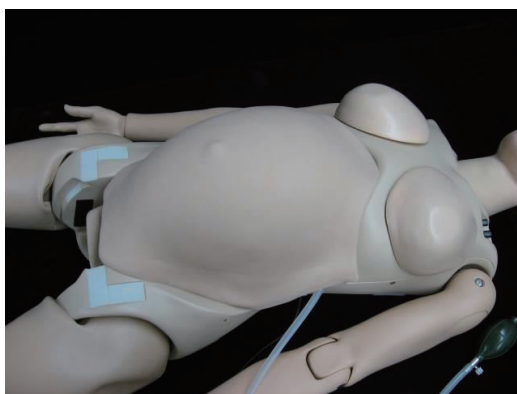

- (2) Place the skin on the manikin only after aligning the underside of the nipples on the skin with the nipples on the surface of the manikin.

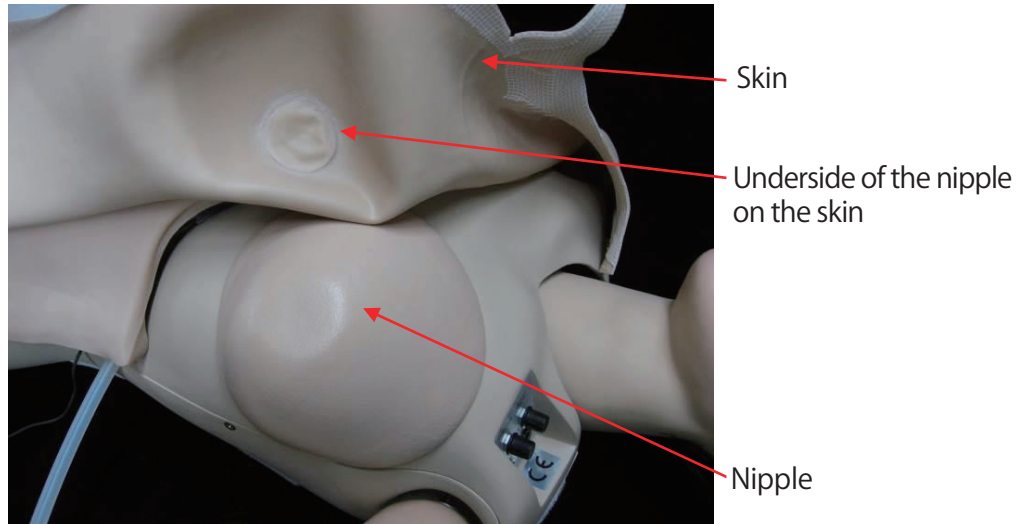

*For fixing the skin in place, two hook and loop fasteners are located on the shoulders, six on the sides, and two on the lower part of the abdomen.



While smoothing down the skin with the hand to eliminate wrinkles on the abdomen, secure it with the hook and loop fasteners.

(3) After setting the skin in place, adjust the volume of air in the amnion while palpating the tension of the amnion.

[REFERENCE]

As the volume of air in the amnion becomes larger, the situation where palpation is more difficult can be simulated. Using a smaller volume of air simulates the situation where palpation is easier. Adjust to suit the situation.

[CAUTION]

When excessive amount of air is injected into the amnion, the amnion may burst. Inject air while checking the tension of the amnion by touching the abdomen of the model.

(4) When finishing adjusting the amount of air in the amnion, close the two-way stopcock in order to avoid an air leak from the amnion.

*If this operation is not performed, the air in the amnion will deflate over time.

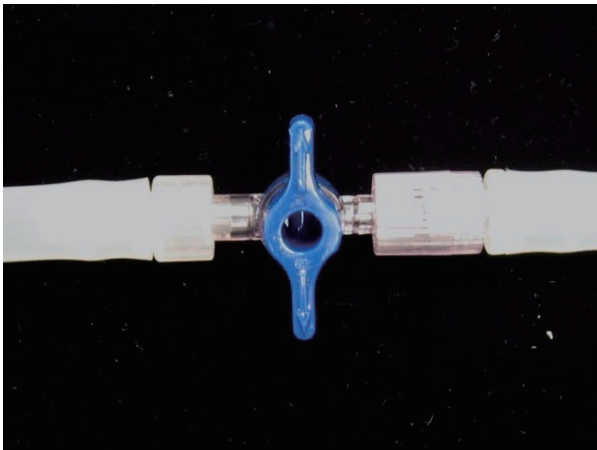

The setting before use is completed.

*Attach the skin to the manikin when practicing nipple massage or breast care.

9. Caring for the Obstetric Abdominal Palpation Model

9-1. Cleaning the main body

(1) To clean smudges or marks off the main body, wipe with a towel or cloth moistened with water.

***Do not wash the main body.**

9-2. Cleaning the skin

(1) If the skin becomes dirty or sticky, wash in water with a neutral solvent. After washing, wipe off all the remaining water with a dry gauze or similar soft cloth, and apply baby powder (accessory).

***Do not clean the skin with rubbing alcohol, thinners, benzene or other similar solvents.**

(2) Pat the skin down with baby powder (accessory) after use and when the skin becomes oily.

9-3. Cleaning the abdominal wall piece

(1) If the abdominal wall piece becomes dirty, wipe with a moist gauze or similar soft material using water or a neutral solvent diluted with water. Then apply baby powder (accessory) liberally to the piece.

***Do not clean the abdominal wall piece with rubbing alcohol, thinners, benzene or other similar solvents.**

9-4. Cleaning the fetus model with amnion and the Seitz method standard adjustment base

(1) To clean smudges or marks off the models, wipe with a moist gauze or similar material using water or a neutral solvent diluted with water.

***Do not clean the models with rubbing alcohol, thinners, benzene or other similar solvents.**

(2) Pat the amnion down with baby powder (accessory) after use and when the amnion becomes oily.

(3) Remove the air from the amnion before storing the fetus model with amnion. When removing air, open the two-way stopcock and twist the valve on the rubber bladder in a counterclockwise manner to loosen it.

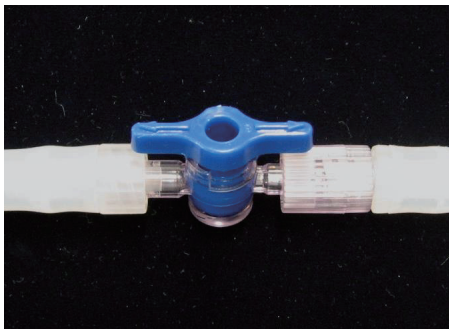

10. Vaginal Examination Model Handling Precautions

1. These models are made with a special material to simulate the texture of human skin. Please handle these models with the same care that you would exercise when working with a human body. Pulling them with excessive force or subjecting them to a strong impact such as dropping may cause damage.
2. The material of the models has a distinct odor. This odor is not harmful to the human body and does not indicate poor quality. The distinct odor fades over time. There may also be a smell of baby powder remaining on the product, as baby powder is applied to the models during fabrication.
3. Wear disposable gloves when using the models.
4. Use glycerin to lubricate. Be sure to apply a sufficient amount of glycerin to the model before use. Koken is not responsible for deterioration or damage occurring from use of lubricants other than glycerin. When all the glycerin provided with the model has been used, please replace it with commercially available glycerin.
5. Placing objects directly on top of the models or placing them on uneven surfaces may cause deformation.
6. Do not use rubbing alcohol, thinners, benzene, or other organic solvents on the model; doing so may cause damage.
7. Do not use oil-based inks, pencils, chalk, or paints on the model as they may cause permanent staining.
8. If the surface becomes sticky after use or after washing, apply baby powder liberally to the models to reduce friction.
9. The models may lose their shape after time. Check the shape of the models approximately three years after purchase. If a model is deformed to the extent that its function is affected, consider replacing it.
10. Air bubbles or impressions in the models that may remain from the fabrication process do not affect the strength of the material because the material used is extremely tear-resistant.
11. Use a 14 Fr gauge or smaller urinary catheter. Be sure to apply glycerin before use.

11. Parts of the Vaginal Examination Model

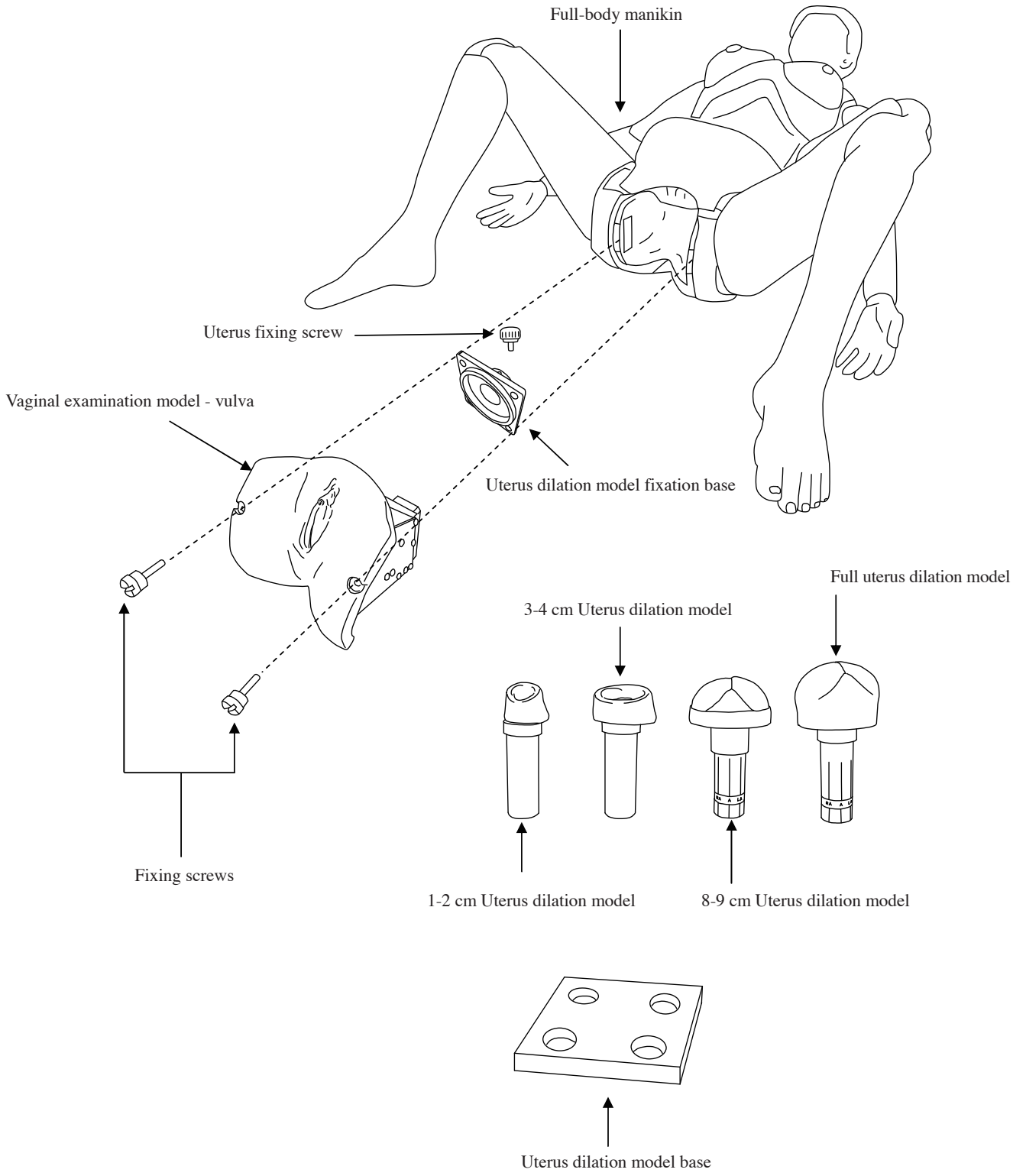

12. Using the Vaginal Examination Model

12-1. Attaching the vaginal examination model - vulva II

Place the vaginal examination model - vulva II, on the full-body manikin, and secure it in place with the fixing screws. (Rotate the screws with a flat-head screwdriver.)

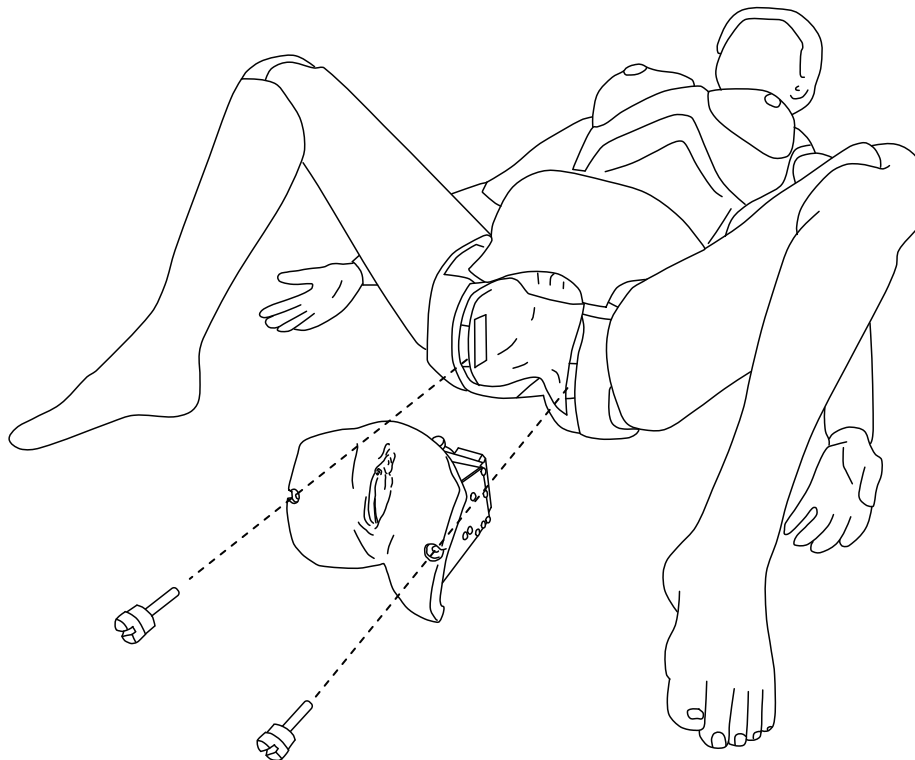

12-2. Removing the vaginal examination model - vulva II from the main body

Remove the fixing screws. Insert your index finger into the space under the anus of the vaginal examination model - vulva II and pull it forward until it detaches.

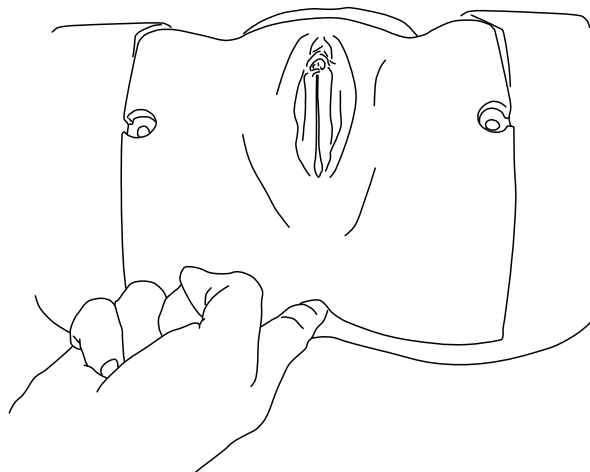

12-3. Applying lubricant

Using your finger, apply a generous amount of glycerin to the vaginal walls and vaginal cavity of the vaginal examination model – vulva II, and to the opening of the uterus dilation model that will be inserted.

*The application of inadequate glycerin may result in damage to the model. Be sure to apply a generous amount.

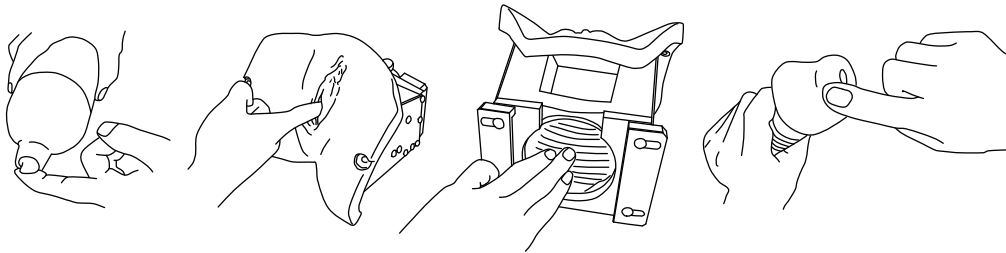

12-4. Setting the 1-2 cm and 3-4 cm uterus dilation models in place

Loosen the uterus fixing screw and insert the uterus dilation model from the direction indicated by the arrow until the model comes in contact with the uterus dilation model fixation plate.

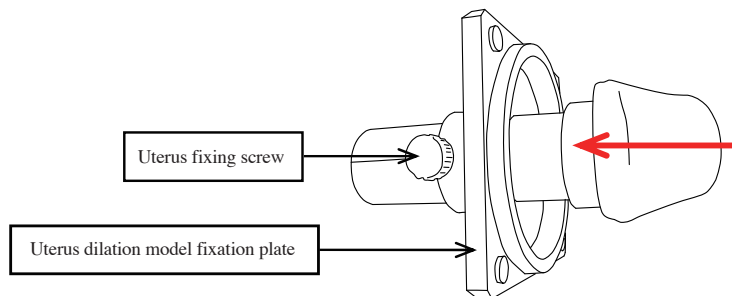

Once the uterus dilation model has been inserted and contacts the uterus dilation model fixation plate, align the line on the uterus dilation model with the line on the uterus dilation model fixation plate. Then, tighten the uterus fixing screw to secure the model in place.

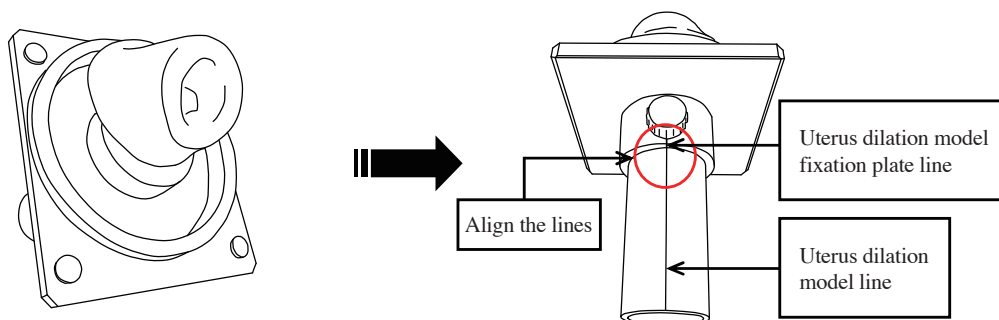

*The fixation point of the cervix is for reference only. The actual fixation point can be adjusted.

*Before removing the uterus dilation model from the uterus dilation model fixing plate, ensure that the uterus fixing screw is loosened.

12-5. Setting the 8-9 cm uterus dilation model and full dilation model in place

- 1) These models are set in place in the same manner as the 1-2 cm and 3-4 cm uterus dilation models, but have to be aligned with the orientation indicators in the bony birth canal.

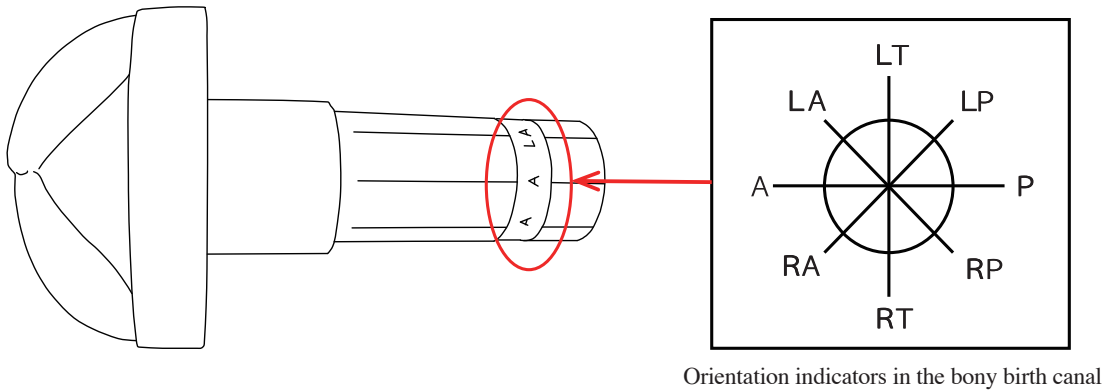

- 2) Line up the uterus dilation model fixation plate line with the orientation indicator line in the bony birth canal to determine the position at which the cervix will be set.

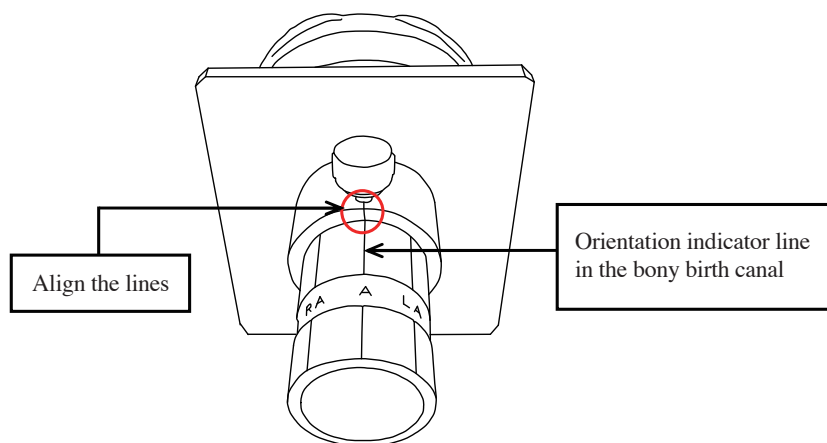

*The fixation point is for reference only. The actual fixation point can be adjusted.

*Before removing the uterus dilation model from the uterus dilation model fixing plate, ensure that the uterus fixing screw is loosened.

12-6. Attaching the uterus dilation model fixation plate to the vaginal examination model - vulva II.

Open the doors on both sides and set the uterus dilation model fixation plate in place with the uterus dilation model secured to it.

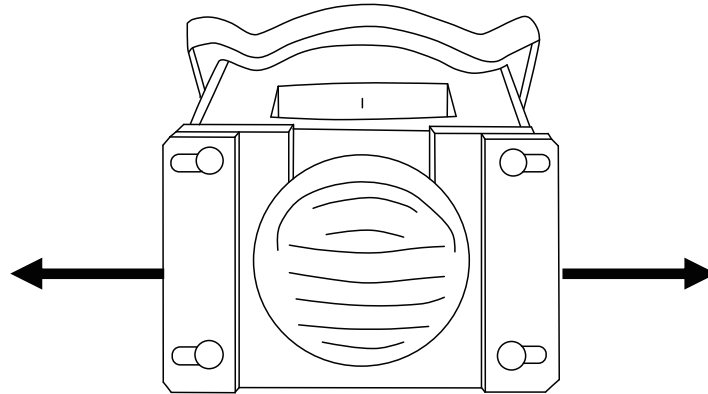

Set the uterus dilation model fixation plate in place with the uterus dilation model secured to it; then, close the doors to secure the plate in place.

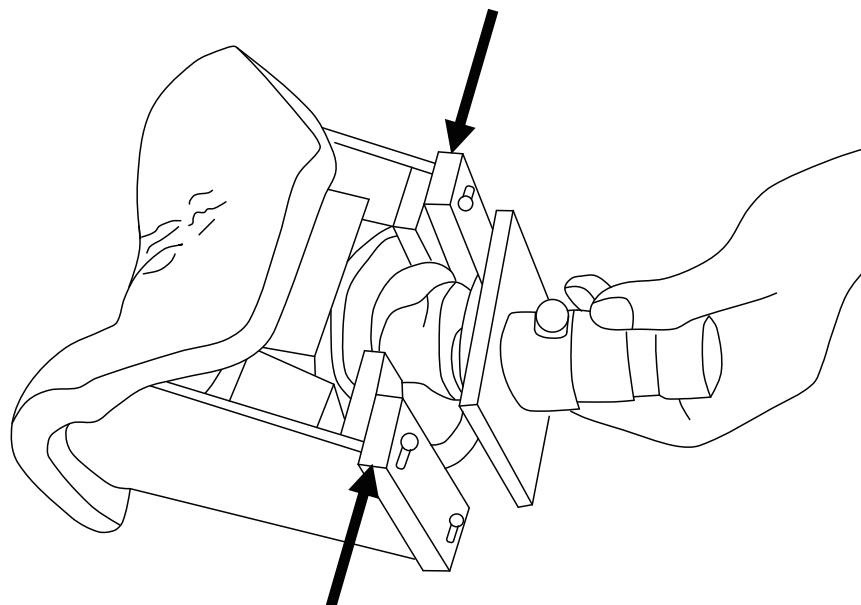

13. Caring for the Vaginal Examination Model

13-1. Cleaning the main body

- (1) To clean smudges or marks off the main body, wipe with a towel or cloth moistened with water.

*Do not wash the main body.

13-2. Cleaning the vaginal examination parts

- (1) To clean smudges or marks on the model, wipe with a moist cloth, gauze, or similar material using water or a neutral solvent diluted with water. Wipe off all the remaining water to prevent the metal parts from rusting. If the metal parts become rusted to the extent that their function is affected, consider replacing them. After wiping off the smudges or marks, apply baby powder liberally to the models.

*Do not clean the model with rubbing alcohol, thinners, benzene or similar solvents.

*Water remaining on the model may cause mold to develop. Make sure to completely wipe off the water.

- (2) Wrap the model in a commercial paper towel, gauze, or another cloth and place it in the re-sealable plastic bag provided as an accessory.

*Storing the models for an extended time in a high or low temperature environment may cause deformation. Exposure to direct sunlight or ultraviolet rays may also cause the material to deteriorate or alter its shape or color. Store the model in a 0-50°C environment, in a place where it will not be exposed to direct sunlight or UV rays.

- (3) The uterusdilation models and other components can be washed in water. After washing, wipe off all the remaining water with a soft, dry gauze or cloth.

14. Obstetric Assistant Model Handling Precautions

14-1. Obstetric model - vulva II and the umbilical cord kit (for tying and cutting)

1. This model is made with a special material to simulate the texture of human skin. Please handle it with the same care that you would exercise when working with a human body. Pulling it with excessive force or subjecting it to strong impact, such as dropping it, may cause damage.
2. The material of this model has a distinct odor, which fades with time. This odor is not harmful to the human body and does not indicate poor quality. There may also be a baby powder smell remaining on the product, as baby powder is applied to the models during fabrication.
3. Wear disposable gloves when handling the model.
4. Use glycerin to lubricate the models. Be sure to apply a sufficient amount of lubricant (glycerin) to the model before use. Koken is not responsible for deterioration or damage occurring from use of lubricants other than glycerin. Use commercially available glycerin if you run out of the glycerin provided with the model.
5. Placing objects directly on top of the models or placing them on uneven surfaces may result in deformation.
6. Do not use rubbing alcohol, thinners, benzene or other similar organic solvents on the model, as doing so may cause damage.
7. Do not use oil-based inks, pencil, chalk, or paints on the model as they will soak into the material and cannot be removed.
8. If the surface becomes sticky after washing the model following use, generously apply baby powder to the model to reduce friction.
9. The model may lose its shape after a long period of time. Check the shape of the model around 3 years after purchase. If it is deformed to the extent that functioning is affected, please consider ordering a replacement.
10. Air bubbles or impressions in the models that may remain from the fabrication process do not affect the strength of the material, as the material used is highly tear-resistant.
11. This model is washable. After washing, wipe off the remaining water with a soft, dry gauze or cloth, and pat baby powder all over the model. (Do not clean the model with rubbing alcohol, thinners, benzene or other similar organic solvents.)
12. Storing the model for an extended time in a high or low temperature environment may result in deformation. Exposure to direct sunlight or UV rays may also alter its shape or color. Store the model in a 0-50°C environment, in a place where it will not be exposed to direct sunlight or UV rays.

- Oil may leak from the model. For proper storage, wrap the model in paper towels, gauze, or another type of cloth, and place it in the re-sealable plastic bag that came with the kit.

14-2. Fetal and placenta models

- Please handle this model with the same care that you would exercise when working with a human body. Excessive force may damage the model.
- When delivering the placenta, avoid pulling too strongly on the umbilical cord.
- Using the umbilical cord clip and hemostatic forceps on the umbilical cord connector may cause it to tear. Use the umbilical cord clip and hemostatic forceps on the replaceable umbilical cord.
- Clamping the model with the base of the grip of hemostatic forceps may tear the model. Avoid using the base of the grip.

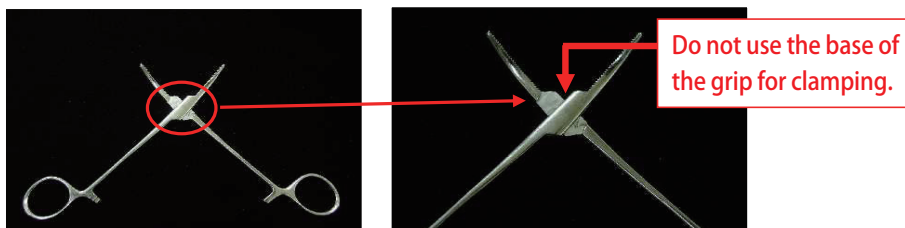

Placenta model – replaceable umbilical cord *Use the umbilical cord clip and hemostatic forceps on this part.

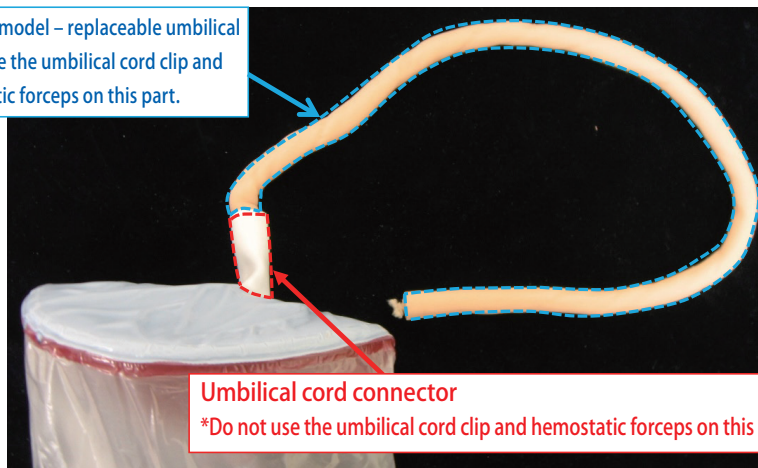

- Wash smudges or marks off the model with water. To clean stubborn smudges or marks, wash with a neutral solvent diluted with water. After washing, wipe off the remaining water with a soft, dry gauze or cloth.
*Do not clean the model with rubbing alcohol, thinners, benzene or other similar solvents.
- Dropping the model or subjecting it to strong impact could cause damage.
- Store the model in a place where it will not be exposed to direct sunlight or UV rays.

15. Parts of the Obstetric Assistant Model

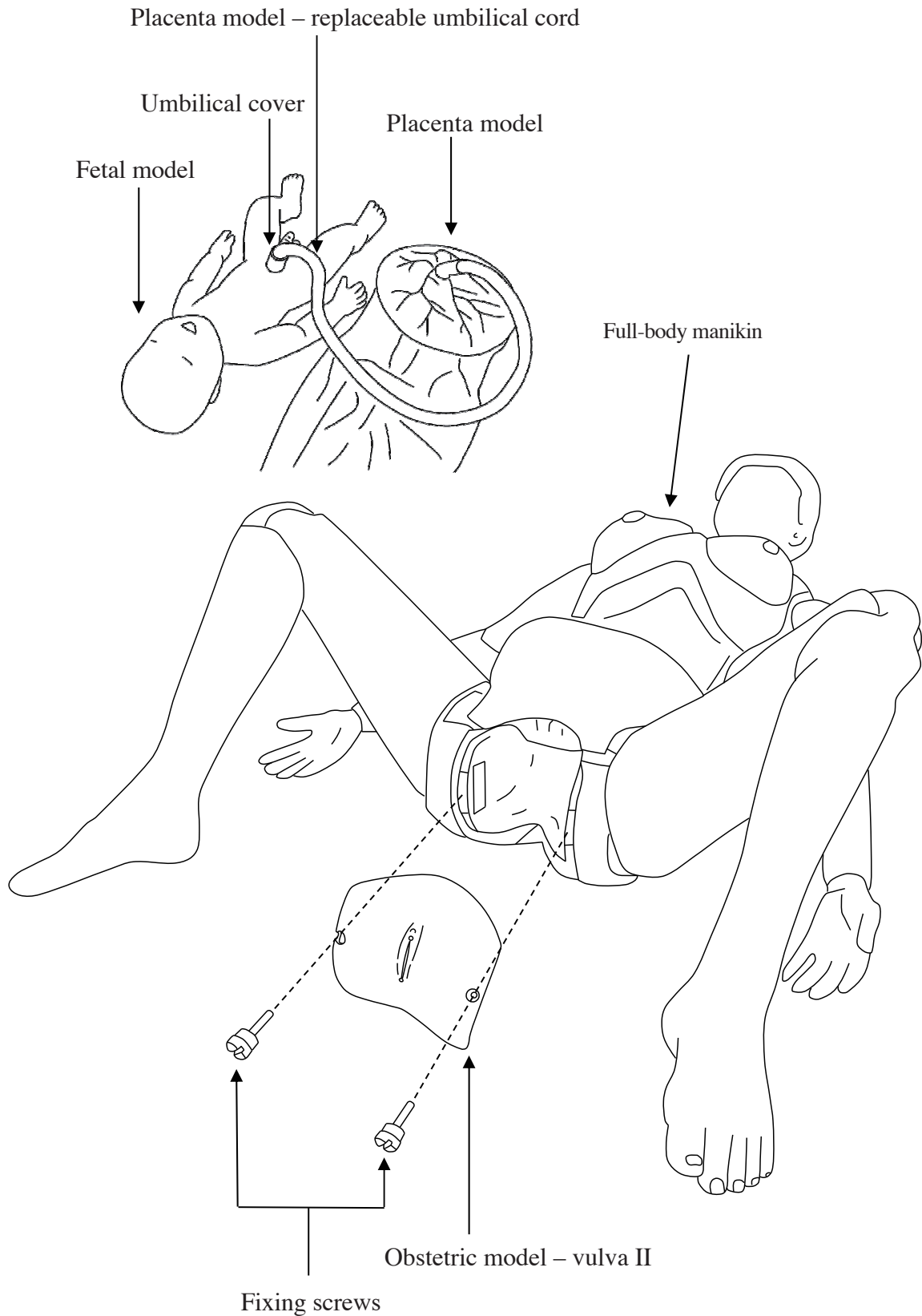

16. Using the Obstetric Assistant Model

16-1. Attaching the obstetric model - vulva II

Attach the obstetric model - vulva II to the full-body manikin, and secure it in place with the fixing screws. (A flat-head screwdriver is required.)

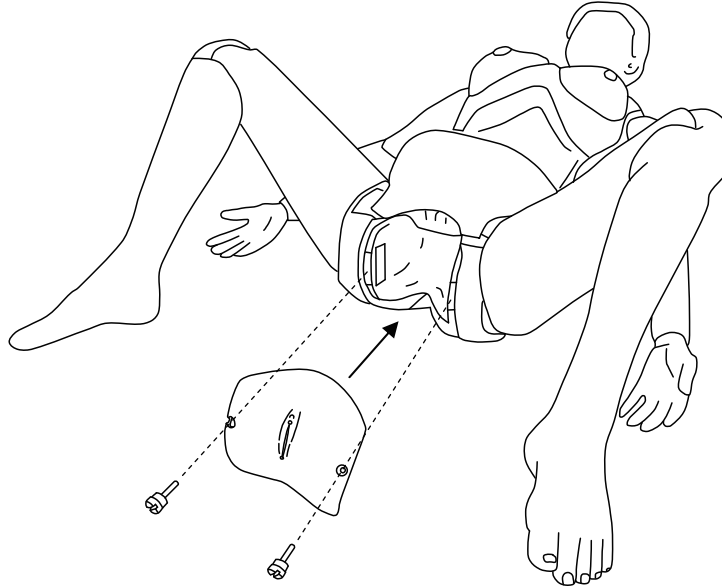

16-2. Attaching the fetal model (LM-114A), placenta model (LM-114B) and placenta model – replaceable umbilical cord (LM-114D)

1. Hold the replaceable umbilical cord and roll down the end with a hole until a ring appears.

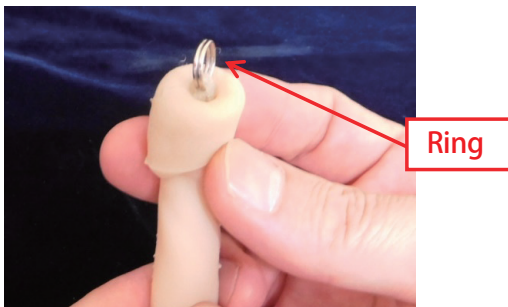

2. Roll down the place for attaching the umbilical cord to the placenta model until a clip appears.

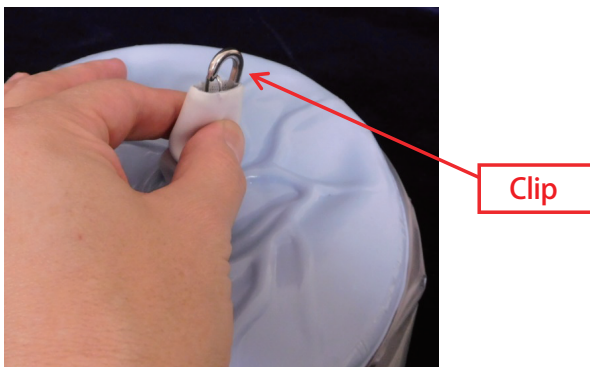

3. Attach the ring on the replaceable umbilical cord to the clip on the placenta model.

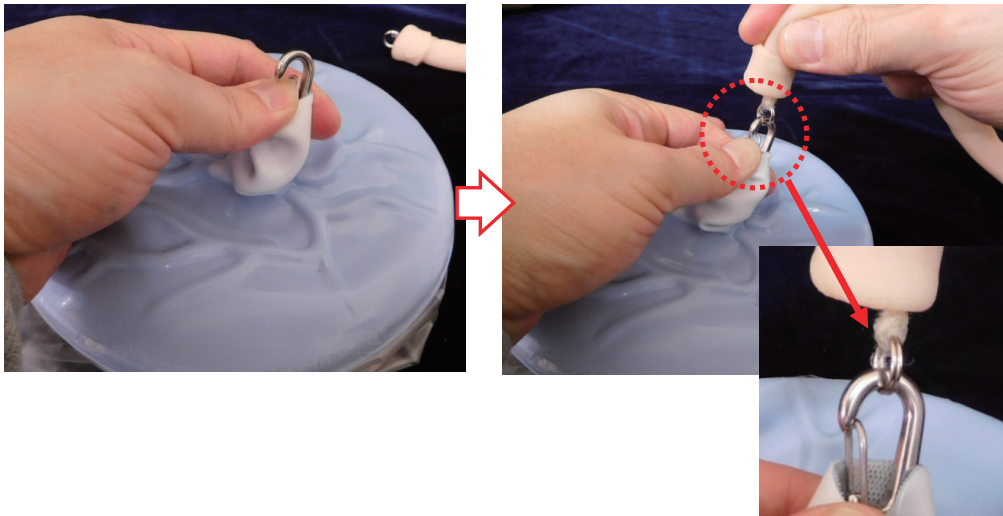

4. Unfold the edges of the replaceable umbilical cord and cover it with the umbilical cord connector of the placenta model.

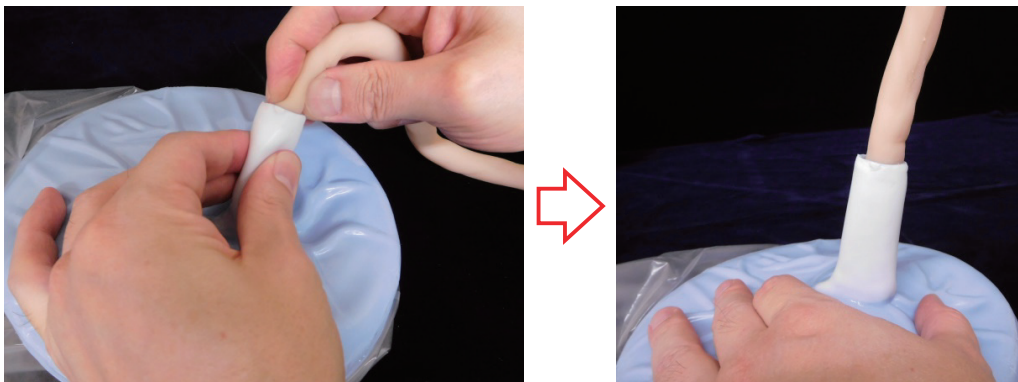

5. Pull out the umbilical cover from the fetal model and slide the umbilical cover towards the knot on the replaceable umbilical cord.

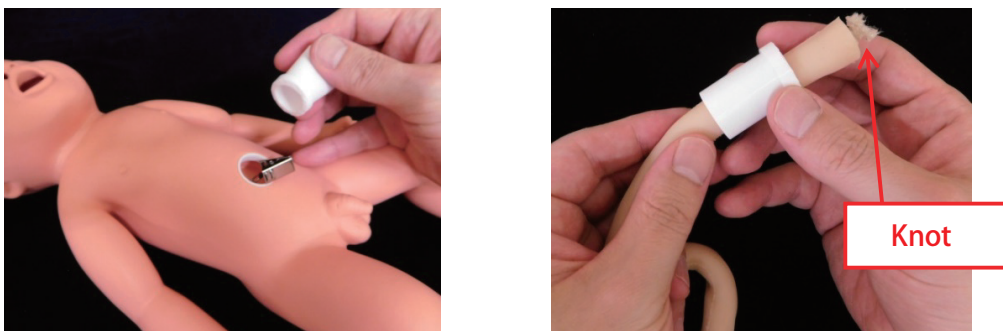

6. Clamp the clip on the fetal model to the knot on the replaceable umbilical cord.

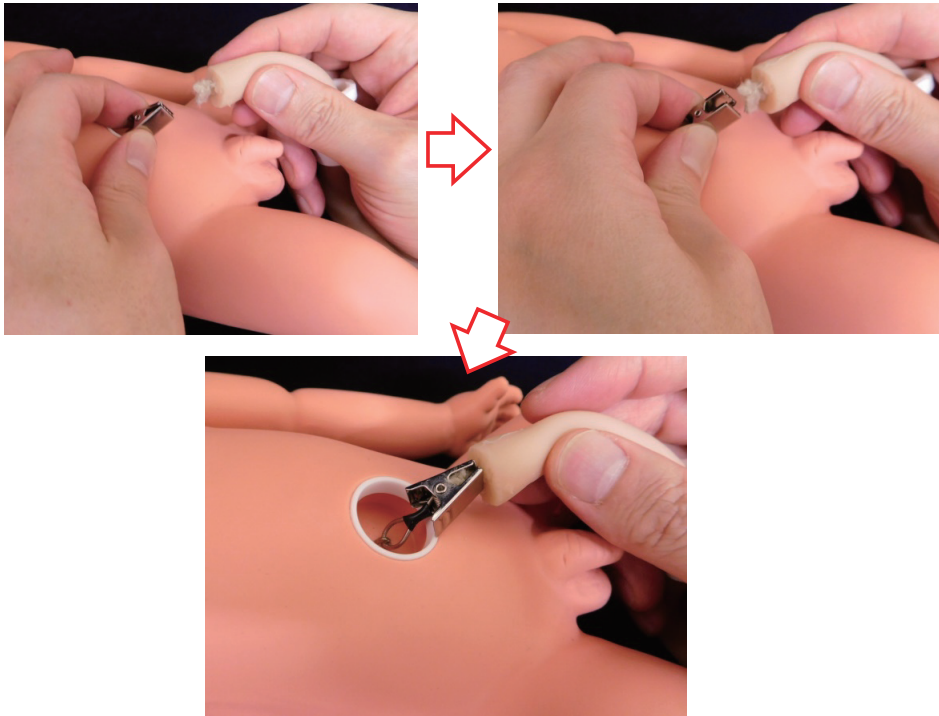

7. Attach the umbilical cover to the fetal model.

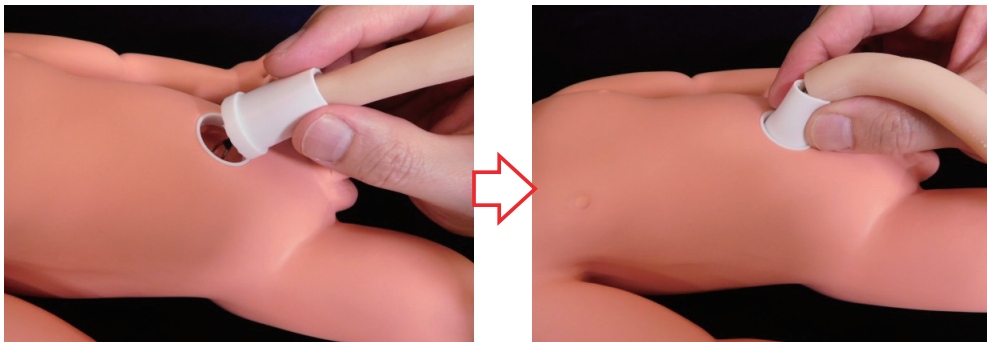

*Internal structure of the fetal model and umbilical cover

The umbilical region of the fetal model has a groove, as shown in the diagram below. Slide the flange of the umbilical cover securely into the groove.

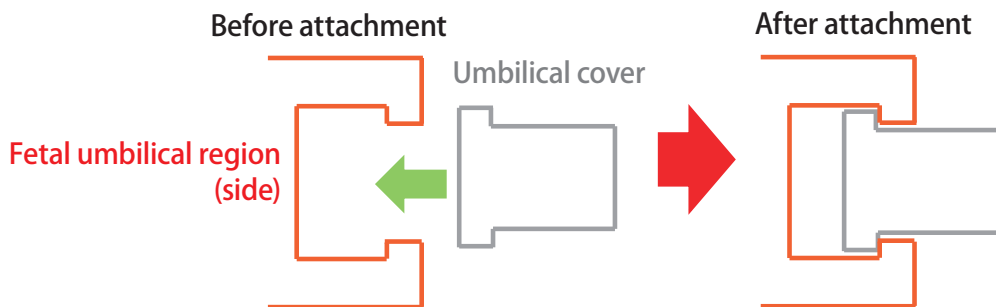

8. The assembly of the fetus, placenta, and umbilical cord is complete.



*Apply a generous amount of glycerin to the fetal and placenta models, and on the inside of the vulva when practicing delivery.

16-3. Applying lubricant

Apply a generous amount of glycerin to the inside of the obstetric model – vulva II; the body of the fetal model, especially the head and shoulders; and over the whole fetal side of the placenta model.

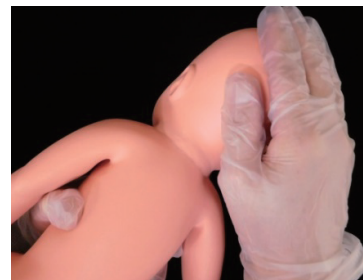

16-4. Holding the fetal model

Hold down the back of the head of the fetal model with your index finger to keep it from facing upwards. Hooking your middle finger over the shoulder of the fetus model will help you do so. The figures below show one way to hold the model.

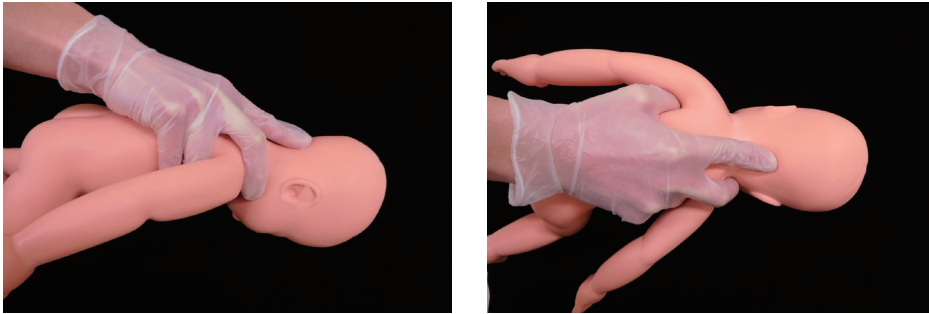

Hold the placenta model as if it is a round ball. Pulling the placenta out in this way will make placenta delivery easier. The figures below show one way to hold the model.



16-5. Tying and cutting the umbilical cord

The umbilical cord clip and hemostatic forceps can be used on the replaceable umbilical cord of the placenta model. The cord can also be cut.



You should only practice tying and cutting the umbilical cord on the replaceable umbilical cord. Practicing these procedures on the umbilical cord connector will cause the model to break.

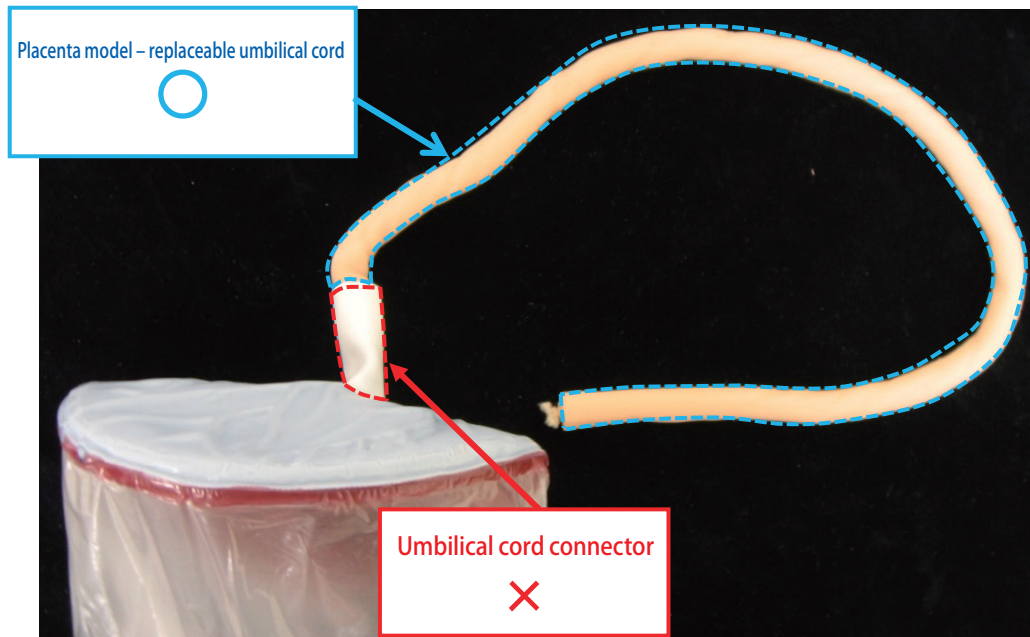

16-6. Attaching the fetus and the umbilical cord after cutting the umbilical cord

Once the umbilical cord is cut, there will no longer be a knot on the umbilical cord, so tie the edge of the umbilical cord with a cable tie, and attach the clip on the fetus to the cable tie.

1. Create a loop with a cable tie and pass the replaceable umbilical cord through this loop.

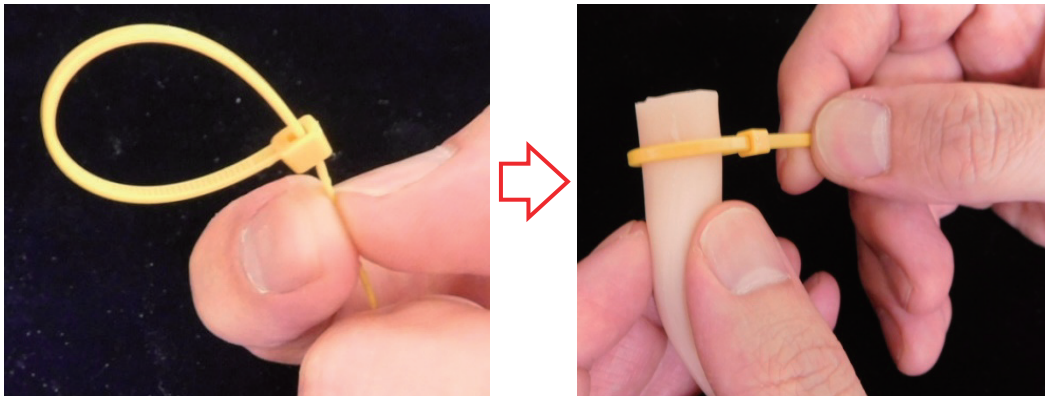

2. Tighten the cable tie securely.

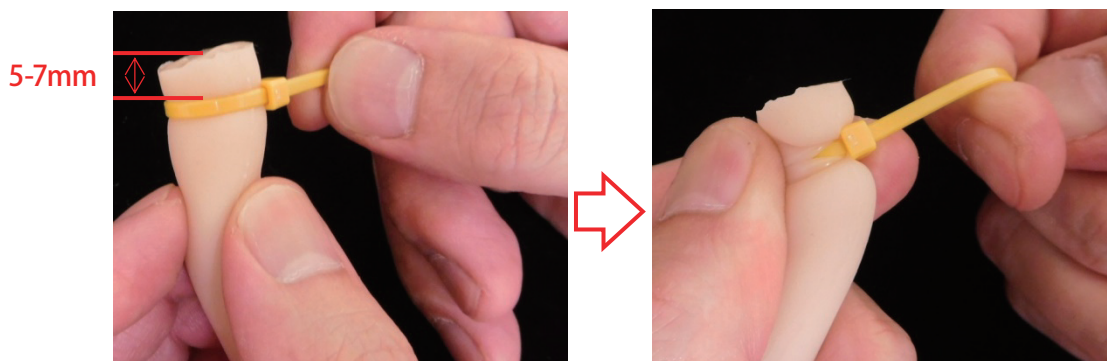

*Looping the cable tie too close to the edge of the umbilical cord may cause the cable tie to slip off. Tighten the cable tie about 5 to 7 mm from the edge of the umbilical cord.

*Performing this procedure when the umbilical cord is lubricated with glycerin will cause the cable tie to slip off, preventing it from being attached to the umbilical cord. Wipe off any lubricant on the umbilical cord before performing this procedure.

*Size of the cable tie

Use a cable tie with a width of about 2 to 3 mm for attaching the umbilical cord. If you use a size that is unsuitable, it may make it difficult to tie the umbilical cord or prevent the clip on the fetal model from being clamped on to the cable tie head

3. Cut the tail of the tightened cable tie near the head.

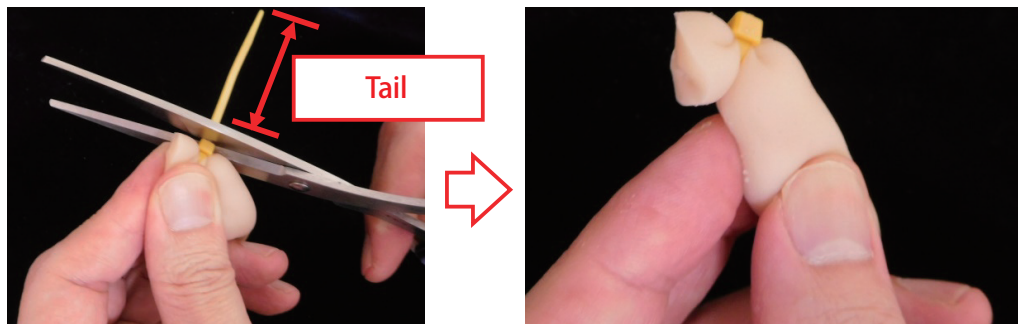

4. Pass the tied umbilical cord through the fetal umbilical cover.

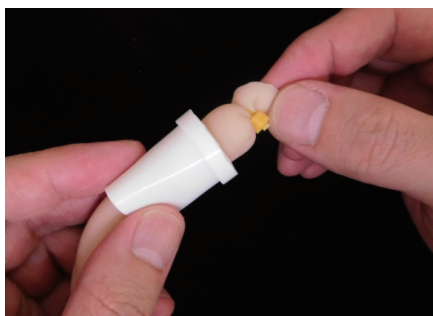

5. Clamp the cable tie head with the clip on the fetal model

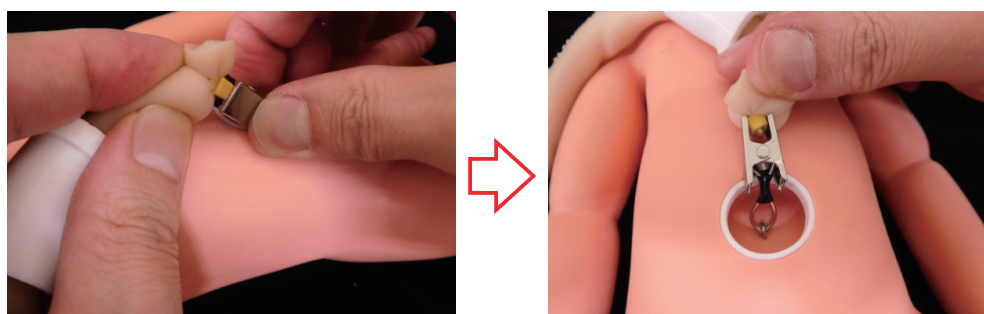

6. Attach the umbilical cover to the fetus to complete the assembly.

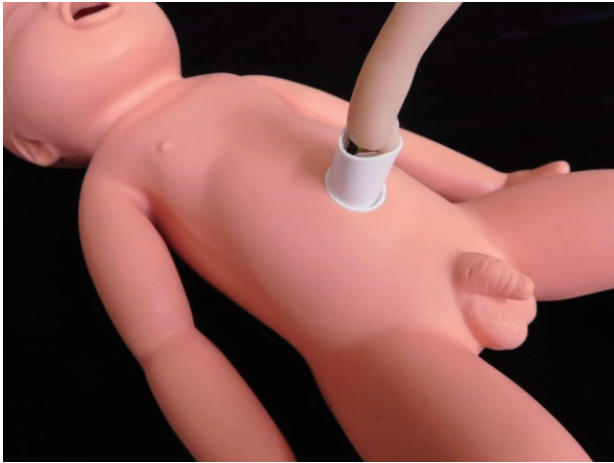

16-7. Using existing products

Delivery can be practiced using existing models: "Fetal Model LM-0633," "Placenta Model LM-0634," and "Parts for Tying and Cutting Umbilical Cords LM-101D" (sold separately). Please read the instruction manuals of the existing models before using them with a full-body manikin.

17. Caring for the Obstetric Assistant Model

17-1. Cleaning the full-body manikin

- (1) To clean smudges or marks off the full-body manikin, wipe with a towel or cloth moistened with water.

*Do not wash the main body with water.

17-2. Cleaning the fetal model and placenta model

Both the fetal model and the placenta model can be washed normally in water.

After washing, wipe off all the remaining water with a soft, dry gauze or cloth.

17-3. Cleaning the obstetric model - vulva II

1. Rub the surface lightly while washing off the lubricant (glycerin) applied during practice with water.

* Do not clean the model with rubbing alcohol, thinners, benzene or other similar solvents.

*When washing the model, do not dig your nails into the surface or apply strong force. This may result in damage.

2. Wipe off the lubricant along with dirt or smudges, and all the remaining water with gauze or a soft cloth. Then, pat baby powder all over the model.

*Water remaining on the model after washing may cause mold to develop. Make sure to thoroughly wipe off all the water.

3. Wrap the model in a commercial paper towel, gauze or other cloth, and place it in the re-sealable plastic bag provided as an accessory.

*Storing the models for an extended period in a high or low temperature environment may cause deformation. Exposure to direct sunlight or ultraviolet rays may also cause the material to deteriorate or alter its shape or color. Store the models in a 0-50°C environment, in a place where they will not be exposed to direct sunlight or UV rays.

18. Perineal Suture Model Handling Precautions

1. Please handle this model with the same care that you would exercise when working with a human body. Excessive force may damage the model.
2. Take care to avoid scratching or putting holes in the perineal suture model - vulva during suture practice.
3. Wash smudges or marks off the model with water. To clean stubborn smudges or marks, wash with a neutral solvent diluted with water. After washing, wipe off all remaining water with a soft, dry gauze or cloth.
*Do not clean the model with rubbing alcohol, thinners, benzene or other similar solvents.
4. Dropping the model or subjecting it to strong impact may cause damage.
5. Store the model in a place where it will not be exposed to direct sunlight or UV rays.

19. Parts of the Perineal Suture Model

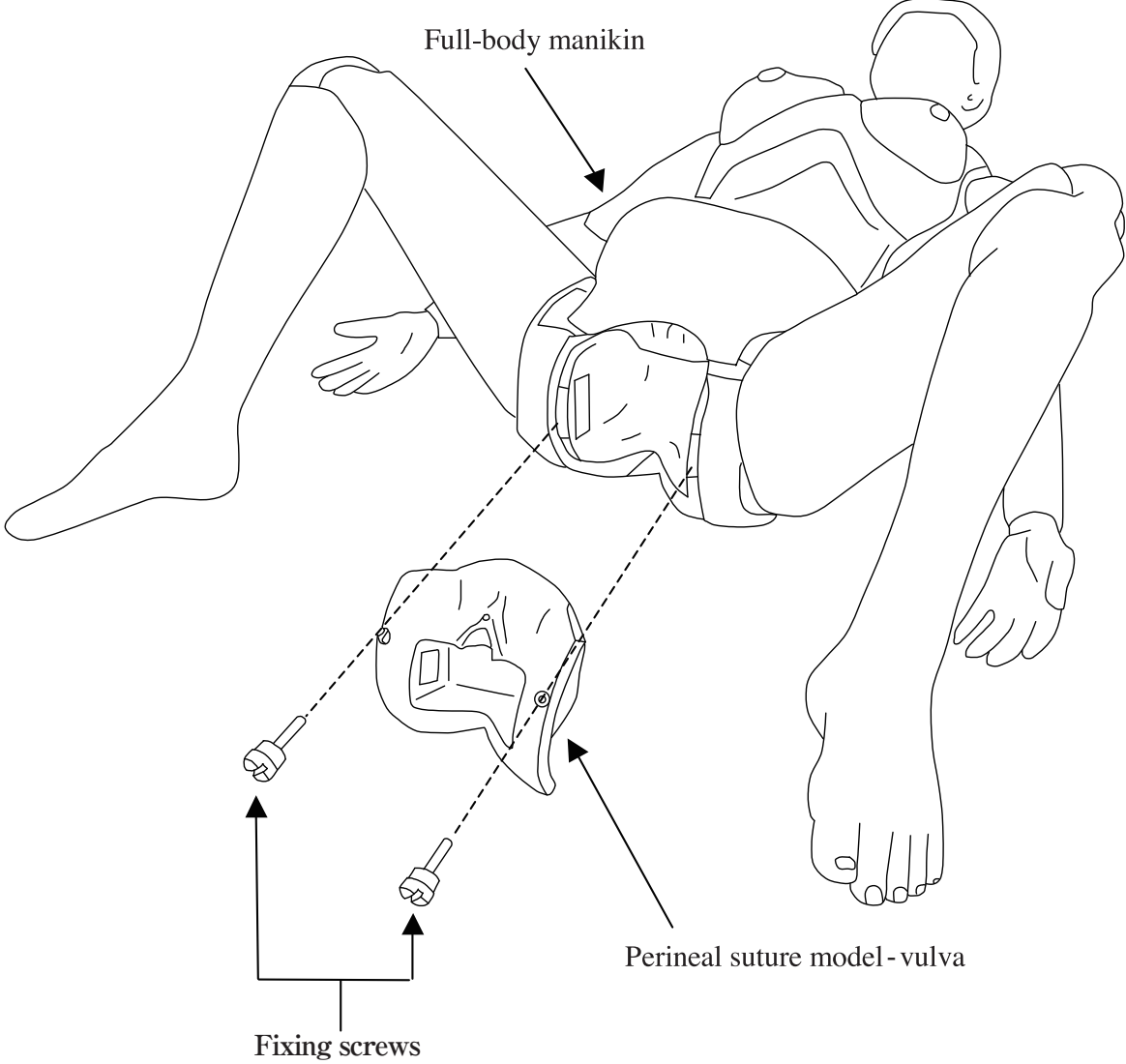

Perineal suture model (left laceration)

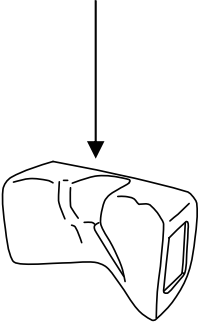

Perineal suture model (right laceration)

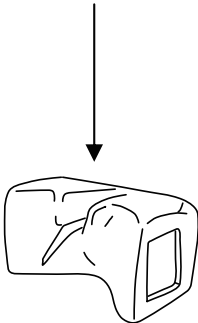

20. Using the Perineal Suture Model

20-1. Attaching the perineal suture model - vulva to the main unit

Line up the hook and loop fasteners on both sides of the perineal suture model to the hook and loop fasteners on the perineal suture model - vulva and set it in place.

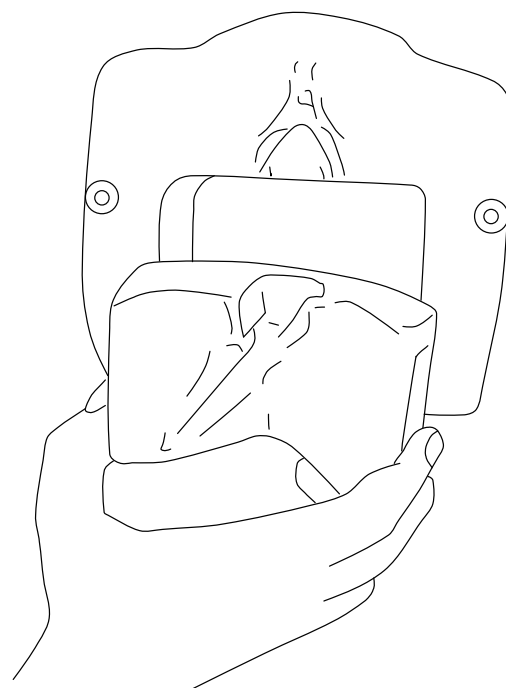
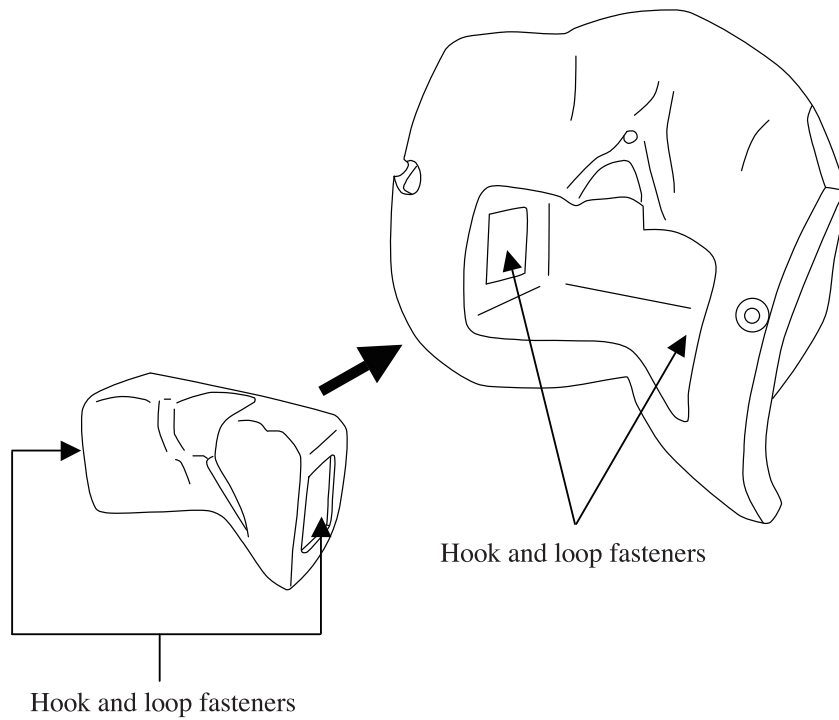

20-2. Attaching the perineal suture model - vulva to the full-body manikin

Insert the perineal suture model - vulva into the full-body manikin, and secure it in place with the fixing screws. (Rotate the screws with a flat-head screwdriver.)

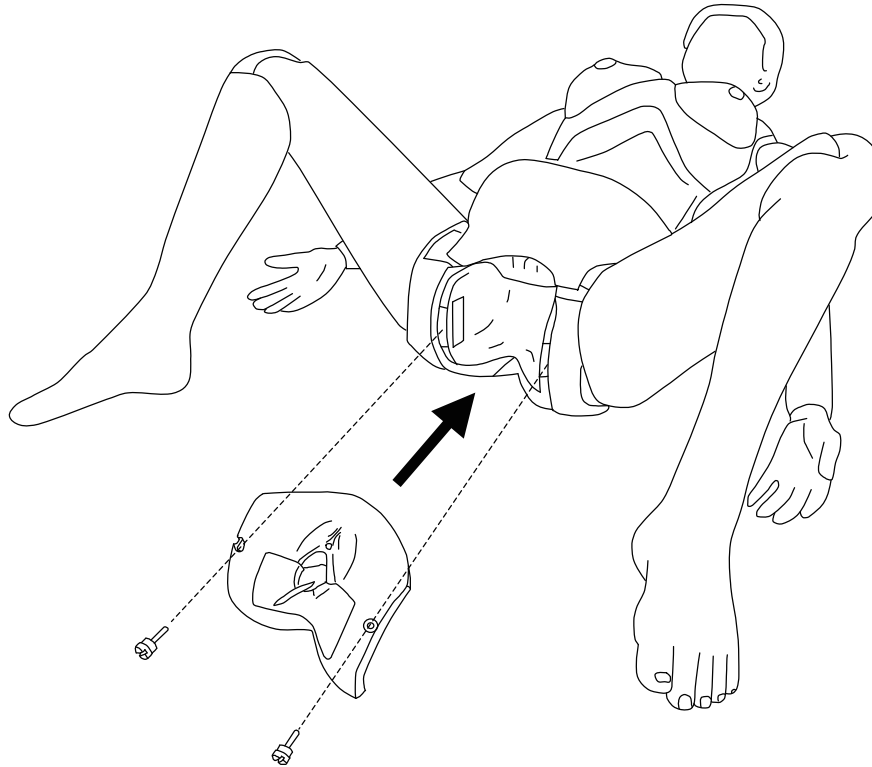

20-3. Removing the perineal suture model vulva from the full-body manikin

Remove the fixing screws. Insert your index finger into the space under the anus of the perineal suture model - vulva. While pushing down on the top of the main body with your right hand, pull the perineal suture model - vulva out towards you until it comes off.

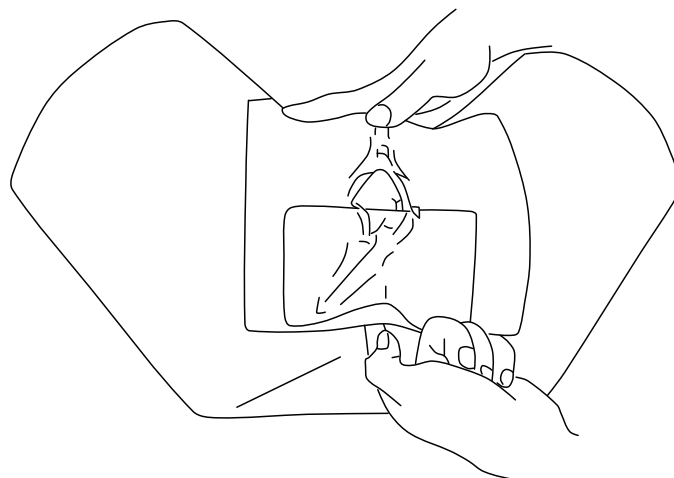

21. Puerperal Uterus Palpation Model Handling Precautions

1. Please handle this model with the same care that you would exercise when working with a human body. Excessive force may damage the model.
2. Do not place objects on top of the abdominal skin. This may result in deformation.
3. To clean smudges or marks, wipe with a moist gauze or similar material using water or a neutral solvent diluted with water.
*Do not clean the model with rubbing alcohol, thinners, benzene or other similar organic solvents.
4. Store the model in a place where it will not be exposed to direct sunlight or UV rays.

22. Parts of the Puerperal Uterus Palpation Model

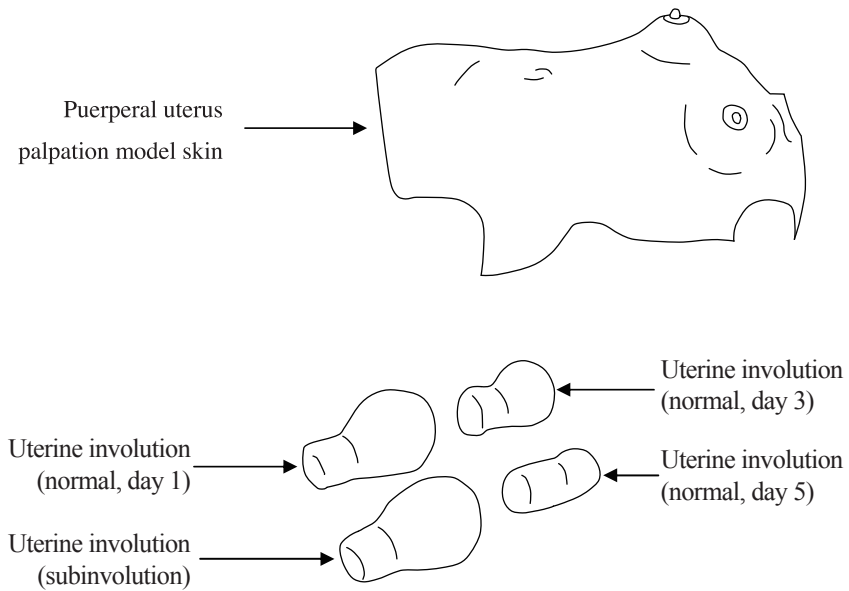

*The uterine involution model (normal, day 1) and the uterine involution model (subinvolution) differ in degree of hardness. The uterine involution model (subinvolution) is made of a softer material than the uterine involution model (normal, day 1).

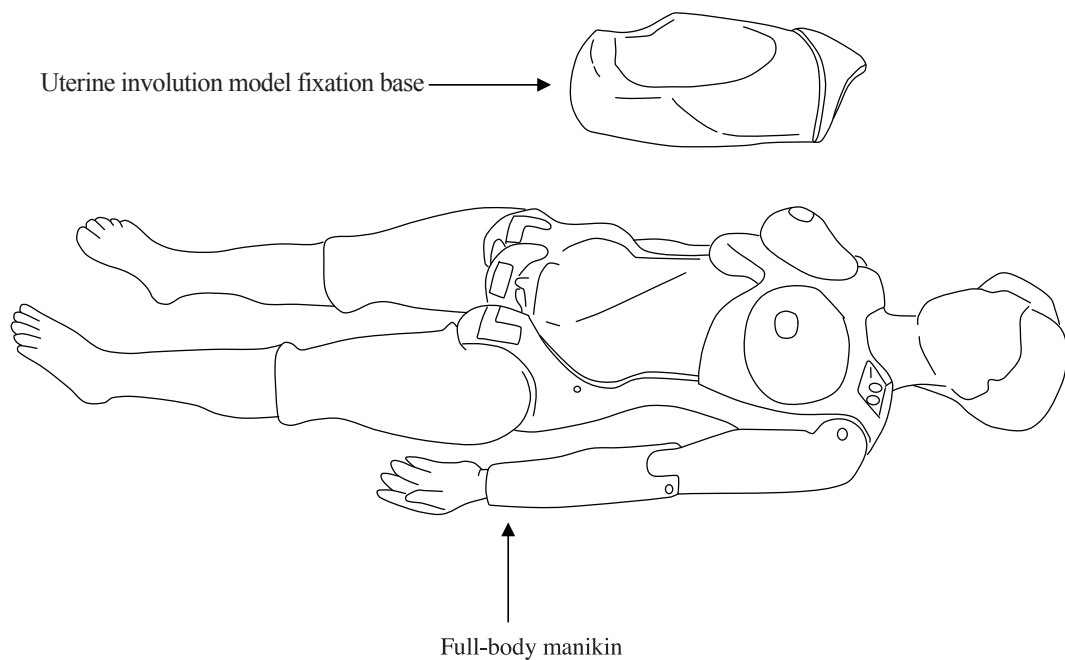

23. Using the Puerperal Uterus Palpation Model

23-1. Placing the uterine involution model fixation base and the uterine involution models

Set the uterine involution model fixation base on the abdomen of the full-body manikin, then set the uterine involution models for palpation on top.

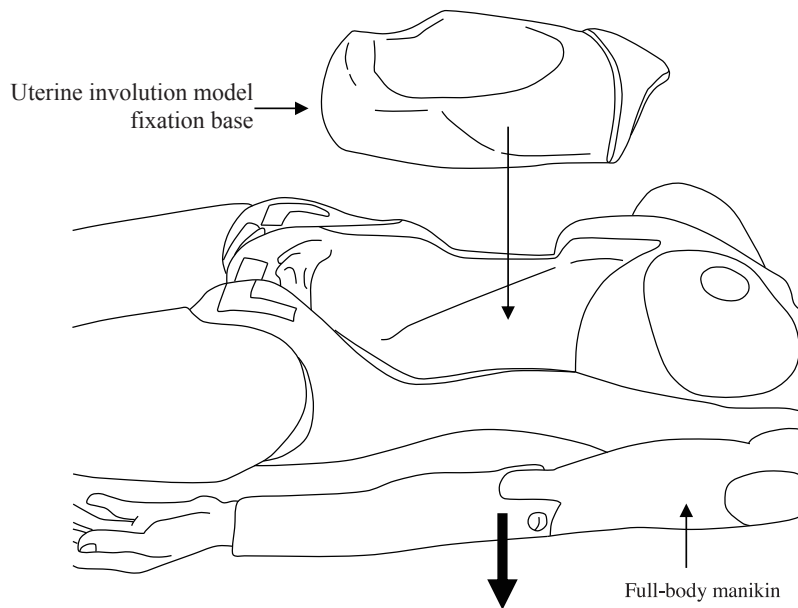

Select one from among the four types of the uterine involution models and set it in place.

***Make sure to apply baby powder before setting it in place.**

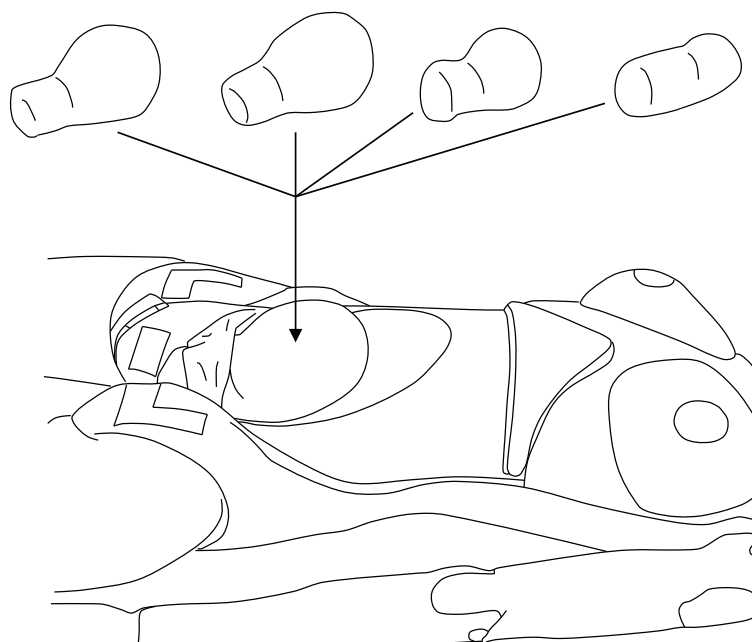

23-2. Attaching the skin for the puerperal uterus palpation model

Align the nipples on the full-body manikin with the underside of the nipples on the skin, then place the skin on the manikin to fit the form. Secure it in place with the hook and loop fasteners in 10 places on the manikin.

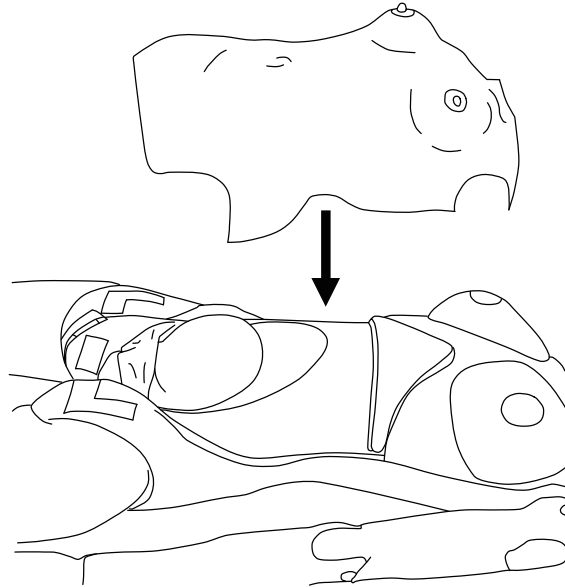

***Place the skin on the manikin only after aligning the underside of the nipples on the skin with the surface of the nipples on the manikin.**

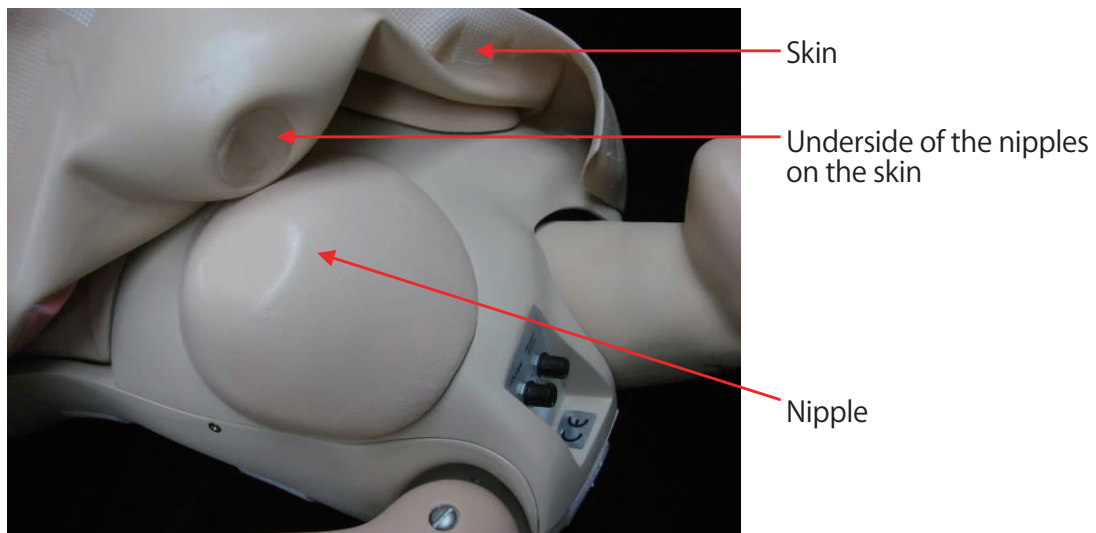

*** For fixing the skin in place, two hook and loop fasteners are located on the shoulders, six on the sides, and two on the lower part of the abdomen.**

***Attach the skin to the manikin when practicing nipple massage or breast care.**

24. Caring for the Puerperal Uterus Palpation Model

1. To clean smudges or marks, wipe with a moist gauze or similar material using water or a neutral solvent diluted with water.

*Do not clean the model with rubbing alcohol, thinners, benzene or other similar solvents.

2. Pat the model down with baby powder (accessory) after use and when the skin becomes oily

25. List of Parts

Main unit	Full-body manikin (with an abdominal cover and fixing screws)	1
Obstetric abdominal palpation parts	Skin II for obstetric abdominal palpation model	1
	Abdominal wall piece	1
	Fetus model with amnion	1
	Two-way stopcock (with Luer fitting)	1
	Seitz method standard adjustment base	1
	Seitz method plus adjustment base	1
	Extension cord for heartbeat generator	1
	Baby powder	1
	Abdominal wall protective sheet	1
	Base	1
	Parts storage bag	3
Vaginal examination parts	Vaginal examination model - vulva II	1
	Uterus dilation model set (4 types)	1
	Uterus dilation model base	1
	Glycerin	1
	Storage case	1
Obstetric assistant parts	Obstetric model - vulva II (primipara type) LM-101P (with a fixing screw *1)	1
	Fetal model	1
	Placenta model	1
	Replacement Umbilical cord for Placenta model (with Binding band x 2)	1
	Glycerin	1
Perineal suture parts	Perineal suture model - vulva LM-0635 (with 1 right laceration and 1 left laceration model)	1
Puerperal uterus palpation parts	Skin for puerperal uterus palpation model	1
	Uterine involution model (4 types)	1
	Uterine involution model fixation base	1
	Baby powder	1
	Parts storage bag	1
Other	Instruction Manual	1

*If the accessory parts storage bag becomes wet (for example, from water or rain), the dye on the lining may run and stain the contents.

*1: The fixing screws are the same for all models.

26. Specifications

Main unit

Product name	Quantity	Length	Width	Height	Weight
Full-body manikin	1	Approx. 177 cm	Approx. 44 cm	Approx. 25 cm	Approx. 17 kg

Obstetric Abdominal Palpation Model

Product name	Quantity	Length	Width	Height	Weight
Skin II for obstetric abdominal palpation model	1				Approx. 670 g
Abdominal wall piece	1				Approx. 1.4kg
Fetus model with amnion	1	Approx. 21 cm	Approx. 32 cm	Approx. 13 cm	Approx. 3,500 g
Air supply tube (with rubber bladder and two-way stopcock): Total length: 109cm					
Seitz method standard adjustment base	1	Approx. 26 cm	Approx. 33 cm	Approx. 12 cm	Approx. 630 g
Seitz method plus adjustment base	1	Approx. 25 cm	Approx. 33 cm	Approx. 14 cm	Approx. 700 g

Puerperal Uterus Palpation Model

Product name	Quantity	Length	Width	Height	Weight
Puerperal uterus palpation model skin	1				Approx. 2 kg
Uterine involution (normal, day 1)	1	Approx. 21 cm	Approx. 14 cm	Approx. 11 cm	Approx. 1 kg
Uterine involution (subinvolution)	1	Approx. 21 cm	Approx. 14 cm	Approx. 11 cm	Approx. 470 g
Uterine involution (normal, day 3)	1	Approx. 16 cm	Approx. 11 cm	Approx. 9 cm	Approx. 660 g
Uterine involution (normal, day 5)	1	Approx. 14 cm	Approx. 7 cm	Approx. 7 cm	Approx. 470 g
Uterine involution model fixation base	1	Approx. 25 cm	Approx. 44 cm	Approx. 14 cm	Approx. 1 kg

Vaginal examination model

Product name	Quantity	Length	Width	Height	Weight
Vaginal examination model - vulva II (with uterus dilation model fixation plate)	1	Approx. 19 cm	Approx. 17 cm	Approx. 15 cm	Approx. 2 kg
1-2 cm uterus dilation model for virtual reality vaginal examination	1	Approx. 5 cm	Approx. 4 cm	Approx. 14 cm	Approx. 100 g
3-4 cm uterus dilation model for virtual reality vaginal examination	1	Approx. 6 cm	Approx. 6 cm	Approx. 13 cm	Approx. 130 g
8-9 cm uterus dilation model for virtual reality vaginal examination	1	Approx. 8 cm	Approx. 8 cm	Approx. 15 cm	Approx. 240 g
Full dilation model for virtual reality vaginal examination	1	Approx. 8 cm	Approx. 8 cm	Approx. 16 cm	Approx. 320 g
Uterus dilation model base	1	Approx. 15 cm	Approx. 15 cm	Approx. 15 mm	Approx. 420 g
Uterus fixing screw	1				

Obstetric assistant model

Product name	Quantity	Size			
Obstetric model - vulva II (primipara type)	1	Length Approx. 17 cm	Width Approx. 17 cm	Height Approx. 8 cm	Weight Approx. 600 g
Fetal model	1	Head circumference Approx. 30 cm		Height Approx. 40 cm	Weight Approx. 2030 g
Placenta model	1	Diameter Approx. 19 cm	Umbilical cord length Approx. 51 cm	Weight Approx. 660 g	
Replacement Umbilical cord for Placenta model	1	Umbilical cord length Approx. 65 cm	Diameter Approx. 1.4 cm	Weight Approx. 80 g	
Fixing screw	2				

Perineal suture model

Product name	Quantity	Length	Width	Height	Weight
Perineal suture model - vulva	1	Approx. 16 cm	Approx. 17 cm	Approx. 12 cm	Approx. 400 g
Perineal suture model (left laceration)	1	Approx. 6 cm	Approx. 10 cm	Approx. 5 cm	Approx. 40 g
Perineal suture model (right laceration)	1				

27. Optional Items

Product name	Model number
Skin II for obstetric abdominal palpation model	LM-101HVB
Abdominal wall piece	LM-101HVC
Vaginal examination model - vulva II	LM-101F
Obstetric model - vulva II (primipara type)	LM-101P
Obstetric model - vulva II (multipara type)	LM-101M
Obstetric model - vulva II (primipara & mutipara type)	LM-101S
Umbilical cord kit (1 umbilical cord connector, 1 umbilical cord)	LM-101D
Umbilical cord for replacement(10 pcs)	LM-101E
Perineal suture model (5 left lacerations and 5 right lacerations)	LM-0636
Fetal model	LM-114A
Umbilical cover	LM-114F
Placenta model	LM-114B
Replacement Umbilical cord for Placenta model	LM-114D

28. Storing the Vaginal Examination Model, Obstetric Assistant Model, and Perineal Suture Model

Upper compartment of the storage case

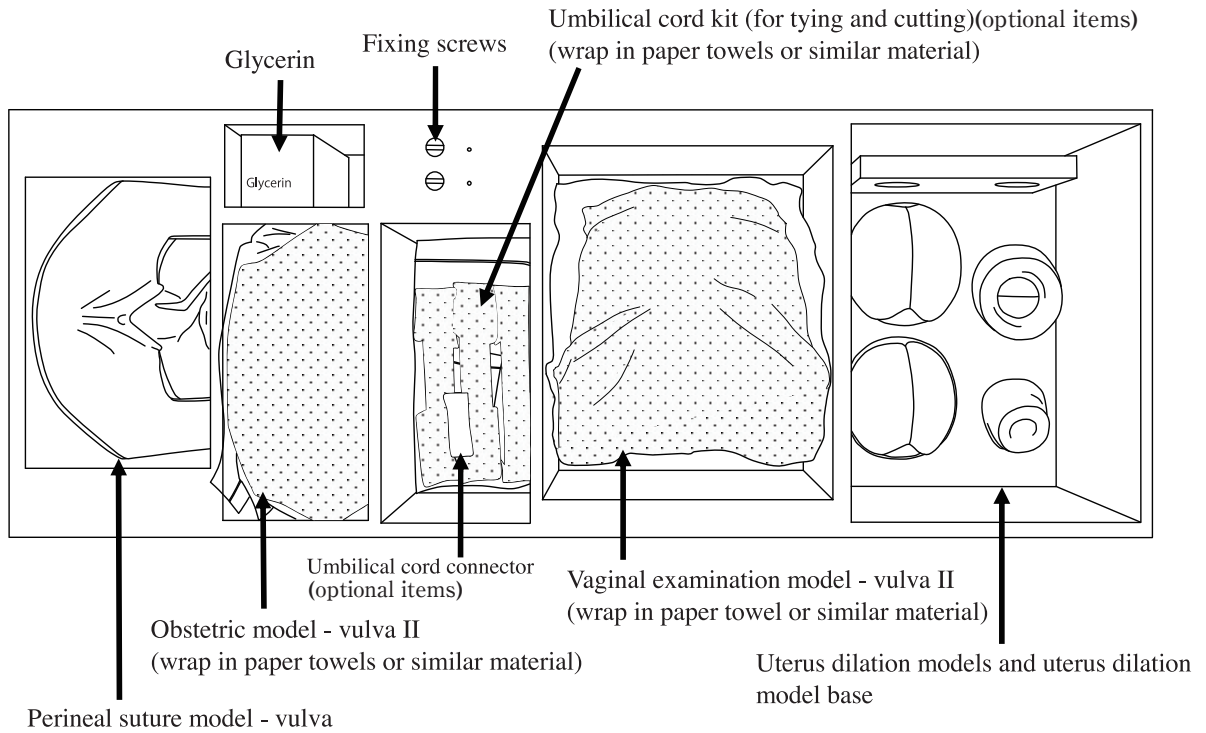

Lower compartment of the storage case

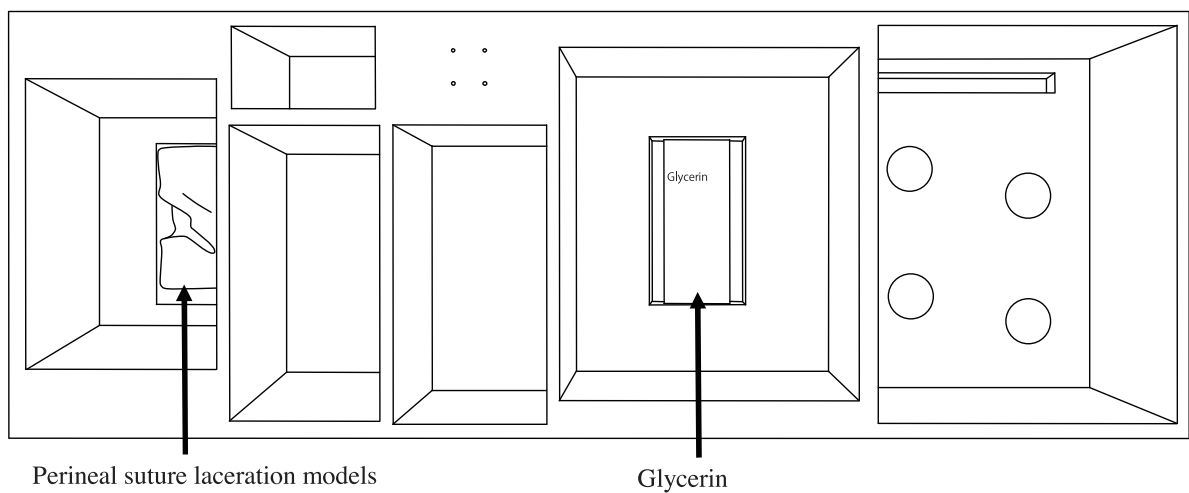

29. Precautions for Unpacking and Storing

Unpacking and storing the manikin must be carried out by at least 2 people.

Removing the product:

1. Remove the foam polystyrene packing blocks (3 pieces) from the cardboard box.

2. & 3. Remove the product while both people simultaneously hold the shoulders and knees.

The product may break if removed by only one person. While doing so, be careful to avoid pinching your fingers or other parts of your body in the joints of the manikin such as the back of the knee.

Storing the product:

Hold the product as shown in 3, and gently place it in the cardboard box.

